

ARO-1130SA

RAID Option Card
for PC Servers
with RAID*port* I or II



Adaptec, Inc.
691 South Milpitas Boulevard
Milpitas, CA 95035

© 1998 Adaptec, Inc.
All rights reserved. Adaptec, and the Adaptec logo are trade-
marks of Adaptec, Inc. which may be registered in some
jurisdictions.

Printed in Singapore
STOCK NO.: 511930-00, Rev. A RQ 3/98

▼▼▼▼ ARO-1130SA

RAID Option Card
for PC Servers
with RAIDport I or II

Installation and Hardware Guide

Copyright

© 1998 Adaptec, Inc. All rights reserved. No part of this publication may be reproduced, stored in a retrieval system, or transmitted in any form or by any means, electronic, mechanical, photocopying, recording or otherwise, without the prior written consent of Adaptec, Inc., 691 South Milpitas Blvd., Milpitas, CA 95035.

Trademarks

Adaptec, the Adaptec logo, AHA, AIC, ARO, Array1000, CI/O, RAID*port*, RAID*port* II, Array*Config*, and SCSI*Select* are trademarks of Adaptec, Inc. which may be registered in some jurisdictions. Windows and Windows 95 are registered trademarks and Windows NT is a trademark of Microsoft Corporation in the U.S. and other countries used under license. All other trademarks are owned by their respective owners.

Changes

The material in this document is for information only and is subject to change without notice. While reasonable efforts have been made in the preparation of this document to assure its accuracy, Adaptec, Inc. assumes no liability resulting from errors or omissions in this document, or from the use of the information contained herein.

Adaptec reserves the right to make changes in the product design without reservation and without notification to its users.

Disclaimer

IF THIS PRODUCT DIRECTS YOU TO COPY MATERIALS, YOU MUST HAVE PERMISSION FROM THE COPYRIGHT OWNER OF THE MATERIALS TO AVOID VIOLATING THE LAW WHICH COULD RESULT IN DAMAGES OR OTHER REMEDIES.

Federal Communications Commission Radio Frequency Interference Statement

WARNING: Changes or modifications to this unit not expressly approved by the party responsible for compliance could void the user's authority to operate the equipment.

This equipment has been tested and found to comply with the limits for a Class B digital device, pursuant to Part 15 of the FCC rules. These limits are designed to provide reasonable protection against harmful interference in a residential installation. This equipment generates, uses, and can radiate radio frequency energy, and if not installed and used in accordance with the instruction manual, may cause harmful interference to radio communications. However, there is no guarantee that interference will not occur in a particular installation. However, if this equipment does cause interference to radio or television equipment reception, which can be determined by turning the equipment off and on, the user is encouraged to try to correct the interference by one or more of the following measures:

- Reorient or relocate the receiving antenna.
- Increase the separation between equipment and receiver.
- Connect the equipment to an outlet on a circuit different from that to which the receiver is connected.
- Consult the dealer or an experienced radio/television technician for help.

Use a shielded and properly grounded I/O cable and power cable to ensure compliance of this unit to the specified limits of the rules.

This device complies with part 15 of the FCC rules. Operation is subject to the following two conditions: (1) this device may not cause harmful interference and (2) this device must accept any interference received, including interference that may cause undesired operation.

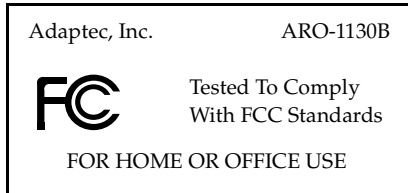

Canadian Compliance Statement

This Class B digital apparatus meets all requirements of the Canadian Interference-Causing Equipment Regulations.

Cet appareil numérique de la classe B respecte toutes les exigences du Règlement sur le matériel brouilleur du Canada.

▼▼▼▼ Contents

1 Introduction

System Requirements 1-2

Installation Overview 1-3

2 Installing ARO-1130SA Hardware

ARO-1130SA Layout 2-2

Verifying Presence of DIMM Memory 2-3

Installing the ARO-1130SA 2-4

 Connecting the LED Cable to the ARO-1130SA 2-5

Completing the Installation 2-6

3 Using the Array1000xA BIOS & Driver Selection Utility

Running the Array1000xA BIOS & Driver Selection
Utility 3-2

4 Creating the First Array With the ArrayConfigSA Utility

Creating an Array 4-2

Making the Array Bootable 4-5

5 Installing Software on a Windows NT Server

Installing the Array1000xA Driver for Windows NT 5-2

 Installing the Driver When Installing Windows NT 5-2

 Installing the Driver When Windows NT is Already
 Installed 5-4

Installing Adaptec CI/O Management Software for
Windows NT Server 5-5

6 Installing Software on a Novell NetWare Server

Installing the Array1000SA Driver for Novell NetWare 6-2

 Installing the Driver When Installing NetWare 6-2

 Installing the Driver When NetWare is Already
 Installed 6-5

Installing the TIRPC Communications Module 6-6

 NetWare 3.12 6-6

 NetWare 4.11 6-6

Installing the Adaptec CI/O Management Software for
Novell NetWare 6-7

 Adaptec CI/O Management Software Installation
 Hints 6-8

7 Installing Software on a Remote Client

Installing Adaptec CI/O Management Software 7-2

 Hints for Establishing Communications With Your
 Server 7-3

A Configuring ARO-1130SA with the SCSI*Select* Utility

Starting the SCSI*Select* Utility A-2

 Using SCSI*Select* Menus A-2

 Exiting SCSI*Select* A-3

 Using the SCSI Disk Utilities A-3

SCSI*Select* Settings A-4

 SCSI Bus Interface Definitions A-4

 SCSI Device Configuration A-5

 Additional Options A-6

B Using the ARO-1130SA with Other Adaptec Products

Using Driver Disk B B-2

Using the ARO-1130SA with an AHA-294x, AHA-3940, or Other AIC-78x0 Based Host Adapter and Driver Disk B (Windows NT Only) B-2

Scenario #1: Adding an ARO-1130SA to a RAIDport I or II System with an AHA-294x, AHA-3940, or Other AIC-78x0 Based Host Adapter B-3

Scenario #2: Adding an AHA-294x, AHA-3940, or Other AIC-78x0 Based Host Adapter to a RAIDport I or II System with an ARO-1130SA B-6

Backing up the Windows NT Registry B-10

C Troubleshooting

Troubleshooting Checklist C-1

Problems Running the Software On Your Windows NT Server C-2

Problems Running SNMP Agent on Your Windows NT Server C-4

D Using a CD-ROM Drive

Using a CD-ROM Drive with DOS D-1

Using a CD-ROM Drive with NetWare D-5

E Using the SNMP Agent

NetWare E-1

Windows NT E-2

Loading MIBs in the MIB Database E-3

Index



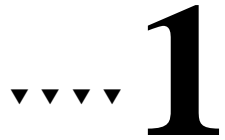

Introduction

The Adaptec® ARO™ -1130SA RAID Option card provides powerful disk array support in servers that have an available PCI/RAIDport I or II expansion slot on the system motherboard.

This *Installation and Hardware Guide* explains how to install the ARO-1130SA, run the Array1000xA BIOS & Driver Selection Utility, create the first array, and then install the supporting software. The *Adaptec CI/O Management Software User's Guide*, which is included with the ARO-1130SA, explains how to use the software to create and manage additional arrays.

System Requirements

The minimum system requirements for the ARO-1130SA are

- An IBM PC (or compatible) server with an available PCI/RAIDport I or II slot



Note: The ARO-1130SA supports all previous versions of RAIDport, including I and II. Refer to the Adaptec Web Site at <http://www.adaptec.com/raid> for an updated compatibility list.

- A minimum of one SCSI hard disk drive
- A standard 168-pin EDO 3.3v, 60ns or faster DIMM installed on the card. (A DIMM is typically pre-installed.) See the Adaptec Web Site at <http://www.adaptec.com/raid> for a list of approved DIMMs and vendors.
- Five MBytes of free hard disk space for the ARO-1130SA software (five MBytes of free hard disk space on the Windows system disk are also required for the temporary files created during installation of the software)
- Windows NTTM 4.0 Server, or Novell NetWare 3.12 or 4.11
- A 3.5-inch 1.44-MByte primary (boot) floppy disk drive
- 32 MBytes or more of system memory
- CD-ROM drive recommended for installation of Adaptec CI/OTM Management Software

Installation Overview

To install ARO-1130SA hardware and software, follow these steps:

- 1 Locate the PCI /RAIDport I or II expansion slot on the motherboard. (Chapter 2)
- 2 Install the ARO-1130SA into the PCI/RAIDport I or II expansion slot. (Chapter 2)
- 3 Connect any additional SCSI devices to the RAID ready SCSI connectors on the motherboard.
- 4 Run the Array1000xA BIOS & Driver Selection Utility. (Chapter 3)



Note: If you plan to install ARO-1130SA in a system containing another Adaptec product, and the Array1000xA BIOS & Driver Selection Utility determines you require Disk B of the manager set driver diskettes, see Appendix B before continuing with installation.

- 5 Create the first bootable array using the ArrayConfigSA™ Utility. (Chapter 4)
- 6 Install the Array1000SA driver for your operating system. (Chapter 5 and Chapter 6)
- 7 Install the Adaptec CI/O Management Software on your server. (Chapter 5 and Chapter 6)
- 8 Install the Adaptec CI/O Management Software on your networked client (optional). (Chapter 7)



Note: Before proceeding with installation, review the *readme* file found on Disk 1 of the Adaptec CI/O Management Software for Windows NT diskettes, or the *readme* file on the `\\wintl\\disk1` directory of the Adaptec CI/O Management Software CD-ROM.



Installing ARO-1130SA Hardware

This chapter explains how to install the ARO-1130SA. To install the ARO-1130SA, you must

- Verify presence of DIMM memory
- Back up any existing data on drives to be used in array
- Install the ARO-1130SA in your server



Note: If the Array1000xA BIOS & Driver Selection Utility (Chapter 3) determines you require driver Disk B of the manager set driver diskettes, see Appendix B, *Using the ARO-1130SA with Other Adaptec Products*.

ARO-1130SA Layout

Figure 2-1 identifies the major ARO-1130SA components. You may find it helpful to refer to this information while installing the ARO-1130SA.

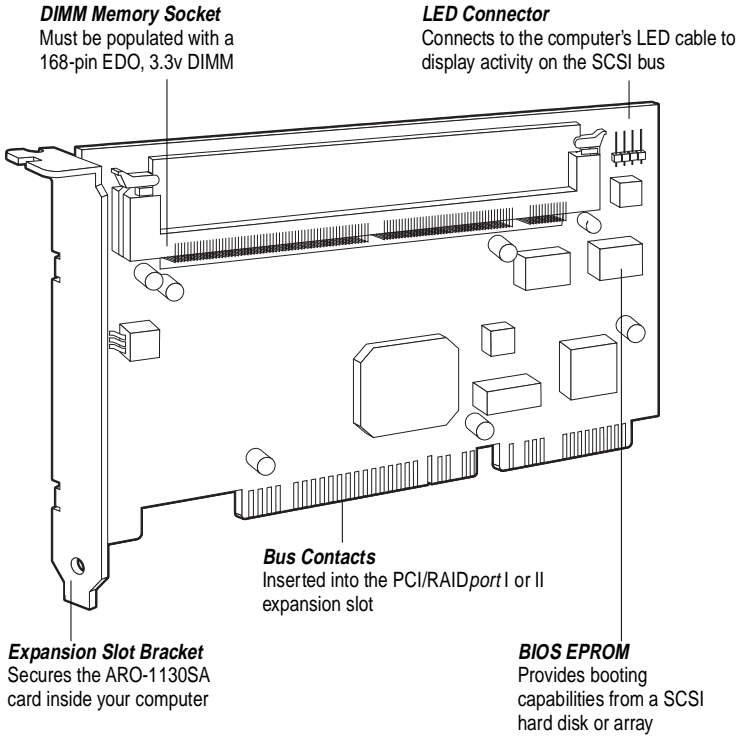

Figure 2-1. ARO-1130SA Major Components

Verifying Presence of DIMM Memory

Before you can use the ARO-1130SA, the DIMM memory socket must be populated with a DIMM, as shown in Figure 2-2. In most cases, the ARO-1130SA comes pre-installed with a DIMM. Nevertheless, a 168-pin EDO 3.3v 60ns or faster DIMM can be used. (See the Adaptec Web Site at <http://www.adaptec.com/raid> for a list of approved DIMMs and vendors.)

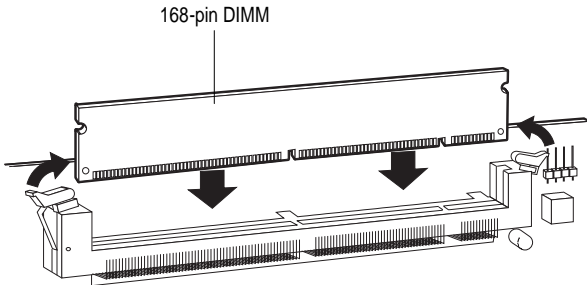

Figure 2-2. Installing a DIMM in the ARO-1130SA DIMM Memory Socket

Installing the ARO-1130SA

Follow these steps to install the ARO-1130SA:



Note: Before installing the ARO-1130SA in an existing server that already has data, back up all data before continuing.

- 1 Turn OFF power to the computer, and disconnect the power cord.
- 2 Remove the cover from the computer case. (If necessary, refer to the instructions in your computer documentation.)
- 3 Locate the PCI/RAIDport I or II expansion slot; unscrew and remove the expansion slot bracket that covers the card-slot opening.
- 4 Insert the ARO-1130SA in the slot; press down firmly so that the bus contacts are securely seated in the slot. Secure the adapter bracket with the screw you removed in Step 3, as shown in Figure 2-3.

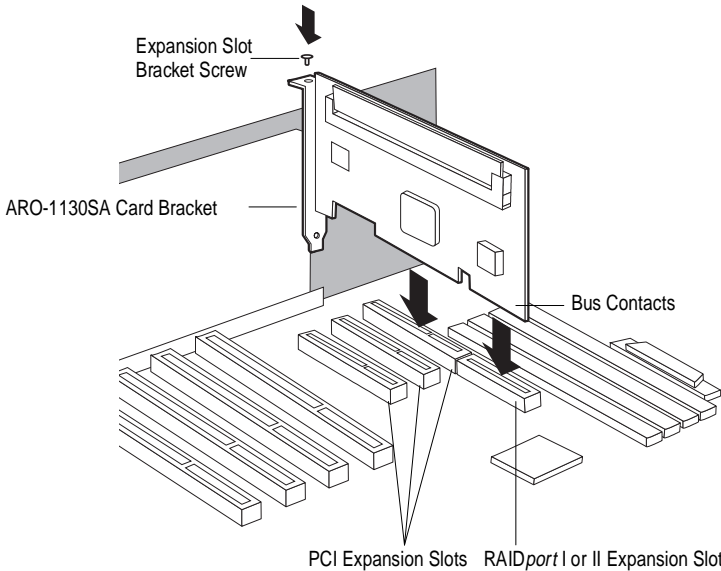

Figure 2-3. Installing the ARO-1130SA in a Typical PCI/RAIDport I or II Expansion Slot

Connecting the LED Cable to the ARO-1130SA

(Optional feature) An LED on the front panel of most computers lights to indicate non-SCSI hard disk activity. If you would like that LED to light whenever there is activity on SCSI Channel A (controlled by ARO-1130SA), disconnect the LED cable from the motherboard and connect it to the LED connector on the ARO-1130SA. If the LED has a two-position cable, connect the cable to pins 1 and 2 of the LED connector, as shown in Figure 2-4.

If the ARO-1130SA supports multiple SCSI channels, and you want the LED to light whenever there is activity on any of those channels, refer to your motherboard documentation for instructions on setting the appropriate motherboard jumpers.



Note: If you are using non-SCSI disk drives (e.g., IDE), the LED may no longer indicate activity on these drives when you connect the LED cable to the ARO-1130SA.

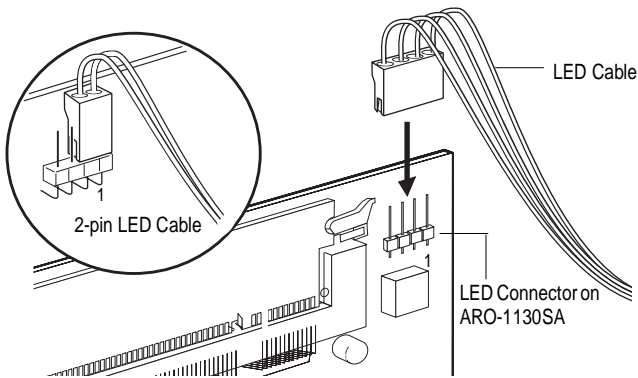

Figure 2-4. Connecting the LED Activity Indicator Cable

Completing the Installation

Once the ARO-1130SA is installed in your server, refer to the documentation that came with your computer and SCSI devices for specific instructions on setting up your SCSI devices and connecting them to the SCSI connectors on the motherboard.



Note: If you refer to the computer's documentation for installation instructions, be sure to return to this document for instructions on running the Array1000xA BIOS & Driver Selection Utility and installing the software included in the package.

In most cases, it is not necessary to run the SCSISelect[®] utility. Should you need to configure SCSI options (e.g., ID, Parity Checking, and Termination), see Appendix A, *Configuring ARO-1130SA with the SCSISelect Utility*.



Using the Array1000xA BIOS & Driver Selection Utility

Whenever you install a new ARO-1130SA in your server and before you run the Adaptec *ArrayConfigSA* program to create the first array in your system, always run the Array1000xA BIOS & Driver Selection Utility.



Caution: We highly recommend that you back up the data on your array(s) before you use the Array1000xA BIOS & Driver Selection Utility. This ensures that your data is completely protected.

The Array1000xA BIOS & Driver Selection Utility installs the ARO-1130SA BIOS by automatically updating (flashing) the correct ARO-1130SA BIOS. The utility also determines which of the two Manager Set driver diskettes (Disk A or Disk B) is required when you install the operating system driver, as explained in Chapter 5 and Chapter 6.

Running the Array1000xA BIOS & Driver Selection Utility

The Array1000xA BIOS & Driver Selection Utility is provided on a bootable floppy disk and runs under DOS as a stand-alone utility. A simple-to-use interface prompts you through the process. Follow these steps to run the Array1000xA BIOS & Driver Selection Utility:

- 1 Insert the Array1000xA BIOS & Driver Selection Utility diskette in drive A and reboot your server. The utility starts automatically and the initial Array1000xA BIOS & Driver Selection Utility screen appears.



Note: The initial Array1000xA BIOS & Driver Selection Utility screen identifies which of the two Manager Set driver diskettes (Disk A or Disk B) are required when you install the operating system driver, as explained in Chapter 5 and Chapter 6. Make a note of which diskette to use, and continue with Step 2.

- 2 Select either **Express** or **Advanced** setup.



Note: If you receive an “Unsupported Hardware Configuration,” message during setup, contact the system manufacturer. The ARO-1130SA is not supported by the system.

- **Express** setup automatically updates the ARO-1130SA BIOS. Select **Express** setup and the utility will do the rest. When prompted, remove the floppy disk and press any key to reboot the server. Continue with the Step 6.
- **Advanced** setup also allows you to update the ARO-1130SA BIOS. In addition, Advanced setup allows you to select other options such as:
 - **Display Current BIOS Checksum.** Determines current version of the ARO-1130SA BIOS.
 - **Display New BIOS Checksum.** Determines version of the BIOS available on the floppy.

- **Save Current BIOS to a File.** Saves the current ARO-1130SA BIOS to a file.
- **Erase Current BIOS.** Erases the current ARO-1130SA BIOS.

To access these options, select **Advanced** setup and continue with Step 3.

- 3** From the Main Menu, select the array adapter card you want to upgrade (only available array adapters can be selected). The Utility Menu appears.
- 4** Make a selection from the Utility Menu.
- 5** Follow the instructions on the screen.
- 6** When prompted, remove the Array1000xA BIOS & Driver Selection Utility diskette from drive *A* and reboot your server.



Creating the First Array With the *ArrayConfigSA* Utility

This chapter explains how to use the *ArrayConfigSA* Utility to create the first bootable or non-bootable array on your server.

Before creating the array, make sure the disks for the array are connected and installed in your server (or array enclosure).



Note: *ArrayConfigSA* runs from a self-booting diskette. If you are changing the configuration of a server that is already in use on a network, log all users off the system and shut it down in an orderly manner before you start *ArrayConfigSA*.

Refer to the *Adaptec CI/O Management Software User's Guide* for additional information.

Creating an Array

Follow these instructions to create the first array with *ArrayConfigSA*:

- 1 Insert the *ArrayConfigSA* diskette in the server's drive *A* and reboot the server. *ArrayConfigSA* starts automatically.
- 2 Select **Disk Array Operations** from the Main Menu.
- 3 Select **Create New Array** from the Disk Array Operations menu.
- 4 Type an array name and press **Enter**. The name can be up to 15 characters long and can include spaces and any other printable characters.
- 5 Select an array type. Your options are
 - **RAID 0**: Data is striped across the disks in a RAID 0 array, allowing for faster I/O performance than a single disk. RAID 0 arrays do not store redundant data; if any disk in the array fails, all data is lost.
 - **RAID 1**: Data is mirrored on one pair of disks. If one disk fails, data is available. The actual data capacity of the array equals half the available disk space.
 - **RAID 5**: The array contains redundant (parity) data distributed across all disks in the array. If any one disk fails, data can be reconstructed from the parity information. If a second disk fails before the array has been reconstructed, all data is lost. The actual usable data capacity of the array is equal to one less than the total number of disks. (One disk's worth of capacity is needed to hold the parity information.)
 - **RAID 0/1**: Data is striped and mirrored on two or more pairs of disks. If one disk in a pair fails, data is available. The actual data capacity of the array equals half the total available disk space.

See the *Adaptec CI/O Management Software User's Guide* for more information on selecting a RAID level.

- 6 Select the number of drives you want in the array and press **Enter**. This number should not include *spares* (drives that automatically replace failed array drives). The number of drives available for assignment is listed on the screen.



Note: This step does not apply to RAID 1 arrays, which have two drives by definition.

- 7 Select array members. When the next screen appears, press **Tab** to highlight a channel (if more than one SCSI channel is available). Select drives for the array by pressing the **↑** and **↓** keys until the drive name is highlighted, and then press **Ins** or **Enter**. The names of selected drives appear in the Adaptec Array # box.

To select drives on a different channel press **Tab** to select another channel and then select the drives from the SCSI IDs on Channel menu. To deselect the drive you most recently added, press **Del**.



Caution: A warning appears if you select a disk that has partitions. *Do not* select a partitioned disk if it contains data you want to keep, because any existing data will be erased when the disk becomes part of the array.

When you have selected the number of drives you specified in step 6, the next screen appears automatically. If you are creating a RAID 1, RAID 0/1, or RAID 5 array, and if there are any unassigned drives, the screen prompts you to define dedicated spare drives for the array. (We recommend that you use a *spare pool* instead of dedicated spares.)



Note: A spare must have at least the capacity of the smallest drive in the array.

- 8 Select spares. If you do not want a spare, type n and continue with Step 10. If you want to select dedicated spares, follow these steps:
 - a At the prompt, type y.
 - b At the next prompt, type 1 or 2.
 - c Select one or two spares, using the same method you used to select disks for the array.
- 9 Initialize array. When the Initialize Mode menu appears, select **Initialize Array to Zero**. Formatting begins immediately. A graph on the screen shows the progress of this operation.



Caution: If the drives contain data, all the data is lost when you initialize the array.

Select **Low-Level Format** only if the drives were previously formatted on another computer or if you think they may have surface defects. Low-level formatting takes a long time for large disk drives.

- 10 Select array block size. When the menu of block sizes appears, select a block size. (This menu does not appear if the array is a mirrored array with only two drives.)

The allowable block sizes are 8, 16, 32, 64 (the default), and 128 KBytes. The default block size gives the best overall performance in most network server environments.

- 11 Wait for initialization to complete. When you see the message Initialization of [array name] is complete, press any key to return to the Disk Array Operations menu.
- 12 Create additional arrays. To create additional arrays (if disks are available), return to Step 3. When all arrays are created, exit *ArrayConfigSA*, remove the *ArrayConfigSA* diskette, and reboot the server. After you reboot you can write data to the arrays.

At this point, you can make your initial array bootable as described in the next section.

Making the Array Bootable

You can make the array bootable so that the server boots from the array instead of from a stand-alone (single) disk.

To make the array bootable, the array must be set to #0 in the boot order. We recommend that you make your initial array bootable. Follow these steps if you want the server to boot from the newly created array:



Note: The server will always attempt to boot from any installed non-SCSI disks (for example, any IDE disk drive at drive C). You must disable or remove all non-SCSI disks if you want the server to boot from a SCSI disk or array.

- 1 Insert the ArrayConfigSA diskette in the server's floppy disk drive A.
- 2 Reboot the server from the diskette. ArrayConfigSA starts automatically.
- 3 Select **Display Boot Order** from the Main Menu. The Boot Order for Singles and Arrays window appears.
- 4 If the newly created array is at the top of the list, preceded by the words Unit 0, no changes are necessary; if it has some other unit number, highlight the array name and press **Enter**.
- 5 Use the arrow keys to move the selected array to the top of the list. Then press **Enter**. If you want to change the boot order of another array, select it, move it with the arrow keys, and press **Enter** again.
- 6 Press **Esc** to return to the Main Menu.
- 7 Exit ArrayConfigSA, remove the diskette from drive A, and reboot the server.
- 8 Prepare the array as you normally would prepare a boot disk drive for your operating system. See either Chapter 5, *Installing Software on a Windows NT Server* or Chapter 6, *Installing Software on a Novell NetWare Server*.



Note: You cannot use this procedure to change the boot order of a SCSI disk drive that is not part of an array. If you want to do this, create a one-disk RAID 0 array from the disk. (Data is not actually striped on a one-disk array.)



Installing Software on a Windows NT Server

This chapter explains how to install the software required to use the ARO-1130SA in a system using Windows NT 4.0 Server.

Before installing the software, make sure the ARO-1130SA is already installed. If you have not already done so, run the Array1000xA BIOS & Driver Selection Utility (see Chapter 3) to determine which of the two Manager Set driver diskettes (Disk A or Disk B) is required to install the Window NT driver. If you plan to boot from an array, make sure the array is already created. To install all of the software, you must complete the following in the order presented:

- Install the *cda1000.sys* driver for Windows NT
- Install the Adaptec CI/O Management Software for Windows NT

Once all software is installed, refer to the *Adaptec CI/O Management Software User's Guide* for instructions on adding, deleting, and managing your arrays.



Note: If your RAIDport I or II system has an additional Adaptec AHA[®]-2940, AHA-3940, or any other AIC[™]-78x0 based host adapter installed (which is not associated with the RAIDport), the driver for these adapters must be from the Adaptec 7800 Family Manager Set 1.3 or later. Furthermore, if the Array1000xA BIOS & Driver Selection Utility determines you require Disk B, refer to Appendix B.

Installing the Array1000xA Driver for Windows NT

This section explains how to install the Adaptec Array1000xA Miniport Driver (*cda1000.sys*) for Windows NT. To begin driver installation, see either *Installing the Driver When Installing Windows NT* below, or *Installing the Driver When Windows NT is Already Installed* on page 5-4.



Note: We recommend that you install your Windows NT operating system on an array to take advantage of the redundancy and performance features of the array.



Note: If your system: 1.) is RAIDport I or II equipped; AND 2.) has an Adaptec AHA[®]-294x host adapter installed; AND 3.) requires driver Disk B (as determined by the Array1000xA BIOS & Driver Selection Utility), see *Using the ARO-1130SA with an AHA-294x, AHA-3940, or Other AIC-78x0 Based Host Adapter and Driver Disk B (Windows NT Only)* on page B-2 for instructions on installing the Array1000CA Miniport Driver.

Installing the Driver When Installing Windows NT

To install the *cda1000.sys* driver when you are installing Windows NT, follow these steps:



Note: If you have multiple arrays, we recommend temporarily powering off all devices except for the boot array before installing Windows NT; otherwise, Windows NT limits the size of the partitions you can create to 1 GByte. When Windows NT installation is complete, power on all devices and reboot the system.

- 1 Start your system with the Windows NT Boot Diskette in the floppy drive or the Windows NT Boot CD-ROM in the CD-ROM drive.



Note: To install Windows NT from a bootable CD-ROM, make sure BIOS Support for Bootable CD-ROM is *enabled* in *SCSISelect*.

- 2** *Windows NT Boot diskette installation:* When prompted, insert diskette #2 in your floppy drive. After a few moments you will see a blue screen. To setup Windows NT now, press **Enter** and continue with Step 3 below.

Windows NT Boot CD-ROM installation: When the following message appears onscreen, press the **F6** key and skip to Step 4 below.

Setup is inspecting your computer system's hardware...

- 3** Press **S** to skip autodetection of your SCSI host adapter.
- 4** Press **S** again to specify an additional device.
- 5** Press **Enter** to select **Others**; insert the Appropriate Adaptec Array1000xA Family Manager Set driver diskette (Disk A or Disk B) in your floppy disk drive and press **Enter**. (See *Running the Array1000xA BIOS & Driver Selection Utility* on page 3-2 to determine the appropriate driver diskette.)
- 6** The screen displays the adapter drivers supported on the diskette. Select the Adaptec Array1000xA Family Adapter driver and press **Enter**.
- 7** If you want to add drivers (other than for the ARO-1130SA), do press **S** and repeat Step 5 for each additional adapter and inserting the appropriate disk provided by the hardware manufacturer.
- 8** Press **Enter** to continue with the Windows NT operating system setup. Follow the instructions onscreen and in the Windows NT documentation to complete the installation.

Installing the Driver When Windows NT is Already Installed

To update or install the *cda1000.sys* driver if Windows NT is already installed, follow these steps:

- 1 Start Windows NT.
- 2 Click the **Start** button on the Windows NT task bar, and then point to Settings.
- 3 Click the **Control Panel**.
- 4 Double-click the **SCSI Adapters** icon.
- 5 Click the **Drivers** tab, and then click the **Add** button.
- 6 In the Install Driver window, click the **Have Disk** button.
- 7 Insert the Appropriate Adaptec Array1000xA Family Manager Set driver diskette (Disk A or Disk B) in your floppy disk drive and press **Enter**; (See *Running the Array1000xA BIOS & Driver Selection Utility* on page 3-2 to determine the appropriate driver diskette.) Enter the following path to the installation files and then click **OK**.

a:\winnt

The Adaptec Array1000xA Family Adapter driver is highlighted by default.

- 8 In the Install Driver window, Click **OK**.
- 9 Click the **New** button when asked if you want to use the currently installed driver(s) or install new one(s).
- 10 Type a:\winnt again, and click **Continue**. The driver is now installed.
- 11 You must restart your computer for the changes to take effect. Click **Yes** to restart your computer.

Installing Adaptec CI/O Management Software for Windows NT Server



Note: The Adaptec CI/O Management Software installation process automatically installs both CI/O server and client components on your Windows NT Server. Before you start the Adaptec CI/O Management Software, be sure that communication with the server via the network is already established. (See the documentation provided with your TCP/IP software for instructions on establishing communications, and also *Hints for Establishing Communications With Your Server* on page 7-3.)

Follow these steps to install the Adaptec CI/O Management Software for Windows NT:

- 1 Start Windows NT.
- 2 Insert the Adaptec CI/O Management Software CD-ROM in your CD-ROM drive. If you are installing the software from diskettes, insert Disk 1 of the Adaptec CI/O Management Software for Windows NT Server in the floppy disk drive.
- 3 Select **Run** from the File menu (Windows NT 4.0 users select **Start**, and then **Run**), type the following and press **Enter**:

`[pathname]setup.exe`

(The `setup.exe` file is located at `\\win_nt\disk1\setup.exe` on the CD-ROM, and at `\\setup.exe` on Disk 1 of the Adaptec CI/O Management Software for Windows NT Server.)

- 4 Follow the directions that appear on the screen.
- 5 When installation is complete, reboot the system. The following NT Services start automatically in the background:

- CIO Array Management Service
- CIOArrayManager RPC Command
- CIOArrayManager RPC EventP
- CIOArrayManager RPC Event
- NobleNet Portmapper



Note: These NT Services are configured to start automatically at boot time. After installation you can start or stop these services through the Services icon in the Windows NT Control Panel.

- 6 Double-click the **Adaptec CI/O Management Software** icon to start the program.

See the *Adaptec CI/O Management Software User's Guide* for information on using the Adaptec CI/O Management Software to add, delete, or manage your arrays. If you are experiencing problems starting the software, see *Problems Running the Software On Your Windows NT Server* on page C-2.



Note: You must have the proper level of Adaptec CI/O Management Software password authorization if you want to add and delete arrays and spares from a networked client. The default password is "adaptec." See the *Adaptec CI/O Management Software User's Guide* for information on setting security options.



Installing Software on a Novell NetWare Server

This chapter explains how to install the software required to use the ARO-1130SA in a Novell NetWare (NetWare 3.12 and 4.11) server. Before installing the software, make sure the ARO-1130SA is already installed. If you have not already done so, run the Array1000xA BIOS & Driver Selection Utility (see Chapter 3) to determine which of the two Manager Set driver diskettes (Disk A or Disk B) is required to install the NetWare driver. If you plan to boot from an array, make sure the array is already created. To install all of the software, you must complete the following in the order presented:

- Install the *cda1000.dsk* driver for Novell NetWare
- Install the TIRPC Communications Module
- Install the Adaptec CI/O Management Software for Novell NetWare

Once all software is installed, refer to the *Adaptec CI/O Management Software User's Guide* for instructions on adding, deleting, and managing your arrays from the server console.



Note: If your RAIDport I or II system has an additional Adaptec AHA-2940, AHA-3940, or any other AIC-78x0 based host adapter installed, the NetWare driver for these adapters must be from the Adaptec 7800 Family Manager Set 1.3 or later. Furthermore, if the Array1000xA BIOS & Driver Selection Utility determines you require Disk B, refer to Appendix B.

Installing the Array1000SA Driver for Novell NetWare

This section explains how to install the Adaptec Array1000SA driver (*cda1000.dsk*) for NetWare. To begin driver installation, see either *Installing the Driver When Installing NetWare* below, or *Installing the Driver When NetWare is Already Installed* on page 6-5.



Note: We recommend that you install your Novell NetWare operating system on an array to take advantage of the redundancy and performance features of the array.



Note: If your system: 1.) is RAIDport I or II equipped; AND 2.) has an Adaptec AHA-294x, AHA-3940, or any other AIC-78x0 based host adapter installed; AND 3.) requires driver Disk B (as determined by the Array1000xA BIOS & Driver Selection Utility), see Appendix B, *Using the ARO-1130SA with Other Adaptec Products*.

Installing the Driver When Installing NetWare

To install the *cda1000.dsk* driver when you are installing NetWare, follow the instructions below for the version of NetWare you are installing.

NetWare 4.11

Follow these instructions only if you are installing NetWare 4.11 for the first time:

- 1 Follow the procedures in your NetWare documentation for installing a new server. (For information on using a CD-ROM drive on a NetWare server, see Appendix D, *Using a CD-ROM Drive* in this installation guide.)
- 2 When a screen appears that asks you to select a disk driver, press **Enter**.
- 3 Press **Insert** to install an unlisted driver.

- 4 Insert the appropriate Adaptec Array1000xA Family Manager Set driver diskette (Disk A or Disk B) into your floppy disk drive. (See *Running the Array1000xA BIOS & Driver Selection Utility* on page 3-2 to determine the appropriate driver diskette.)
- 5 Press **F3** and specify the path to the *cda1000.dsk* driver. For NetWare 4.1, the driver is located in *\netware\lv4_1x* on the diskette.
- 6 Select *cda1000.dsk* and press **Enter**.
- 7 When prompted to save the current version of *aspitran.dsk*, select **Yes** or **No**.
- 8 When prompted to save the current version of *nwpaload.nlm*, select **Yes** or **No**.
- 9 When the message *File "A:\netware\lv4_1x\nwpaload.nlm was not found..."* appears, ignore the message and press **Enter** to continue.
- 10 Select **Continue copying the next file**.
- 11 Select **Yes** to install an additional disk driver.
- 12 Select *aspicd.dsk* and press **Enter**.
- 13 When prompted to so save current version of *aspicd.dsk*, select **No**.
- 14 When prompted to so save current version of *aspicd.ddi*, select **No**.
- 15 Select **No** when prompted to install an additional disk driver.
- 16 Select **Continue Installation**.
- 17 Press **Enter** to continue.
- 18 Down and exit the server. At the DOS prompt, copy the *nwpa.nlm*, *nbi.nlm*, and *nwpaload.nlm* files (located on the Novell Installation CD-ROM) to the server's startup directory (usually *c:\nwserver*).



Note: To load the driver automatically at server bootup, make sure the *startup.ncf* file includes the load command line for the *cda1000.dsk* driver. (If you also have an Adaptec host adapter that uses the Adaptec *aic78xx.dsk* driver, make sure the driver loads after the *cda1000.dsk* driver.)

NetWare 3.12

Follow these instruction only if you are installing NetWare 3.12 for the first time:

- 1 Follow the procedures in your NetWare documentation for installing a new server. (For information on using a CD-ROM drive on a NetWare server, see Appendix D, *Using a CD-ROM Drive*.)
- 2 When you see the NetWare colon prompt (:), use the load command to install the driver from the appropriate Adaptec Array1000xA Family Manager Set driver diskette (Disk A or Disk B). (See *Running the Array1000xA BIOS & Driver Selection Utility* on page 3-2 to determine the appropriate driver diskette.)

The correct syntax to load the *cda1000.dsk* driver is

```
:load [pathname]cda1000
```

(For example, :load a:\netware\v3_1x\cda1000)



Note: To load the drivers automatically at server bootup, copy the *aspitran.dsk* and *cda1000.dsk* drivers to the server's startup directory and modify the *startup.ncf* so that the proper path to the driver is specified.

The *aspitran.dsk* driver must reside in the same path as *cda1000.dsk*, because NetWare attempts to load this file automatically. If you also have an Adaptec host adapter that uses the Adaptec *aic78xx.dsk* driver, make sure the driver loads after the *cda1000.dsk* driver.

- 3 Load the NetWare *install* program from the NetWare colon prompt (:load install). Follow the instructions in the NetWare documentation to complete the installation (e.g., creating disk partitions, system volumes, etc.) of your server.

Installing the Driver When NetWare is Already Installed

To update or install the *cda1000.dsk* driver if NetWare is already installed, follow the instructions in this section. The procedures are similar for all versions of NetWare. Procedures that are specific to a NetWare version are noted when necessary.

- 1 Copy the *cda1000.dsk* and *aspitran.dsk* files from the appropriate Adaptec Array1000SA Family Manager Set driver diskette (Disk A or Disk B) into the server's startup directory (e.g., *c:\nwserver*, *c:\server.312*) on your hard disk drive. (See *Running the Array1000xA BIOS & Driver Selection Utility* on page 3-2 to determine the appropriate driver diskette.)



Note: For NetWare 3.12, the *cda1000.dsk* and *aspitran.dsk* files are located in the *\netware\lv3_1x* subdirectory on the diskette; for NetWare 4.11, the files are in *\netware\lv4_xx*.

- 2 If necessary, modify the load command line in the *startup.ncf* so that the proper path to the driver is specified. The correct syntax to load the *cda1000.dsk* driver is

```
load [pathname]cda1000
```



Note: If you unload *cda1000.dsk* driver, you must also unload *cioams.nlm*. When you load *cda1000.dsk* driver again, you must also load *cioams.nlm*. If *cioams.nlm* is not unloaded when you unload *cda1000.dsk*, your system may work erratically.

Installing the TIRPC Communications Module

The TIRPC communications module must be installed before you install the Adaptec CI/O Management Software. The module allows communications between the server and remote clients. Follow the instructions below for the version of NetWare installed.

NetWare 3.12

- 1 Insert the Adaptec CI/O Management Software CD-ROM in your CD-ROM drive. If you are installing the software from diskettes, insert Disk 1 of the Adaptec CI/O Management Software for NetWare (TIRPC).
- 2 From the NetWare colon prompt (:), type the following and press **Enter**:
load install
- 3 Select **Product Options** from the Installation Options Menu.
- 4 Press the <Ins> key.
- 5 Enter the path to the CD-ROM or Disk 1 (do not include the backslash).
- 6 Select **NetWare 3.x TIRPC Runtime and Configuration Files**. (TIRPC must be installed in the *sys:system* directory only.)

NetWare 4.11

- 1 Insert the Adaptec CI/O Management Software CD-ROM in your CD-ROM drive. If you are installing the software from diskettes, insert Disk 1 of the Adaptec CI/O Management Software for NetWare (TIRPC).
- 2 From the NetWare colon prompt (:), type the following and press **Enter**:
load install
- 3 Select **Product Options** from the Installation Options Menu.
- 4 Select **Install a Product Not Listed**.
- 5 Press <F3> key.
- 6 Enter the path to the CD-ROM or Disk 1 (include the backslash).

- 7 Select **NetWare 4.0 TIRPC Runtime and Configuration Files**. (TIRPC must be installed in the `sys:system` directory only.)

Installing the Adaptec CI/O Management Software for Novell NetWare



Note: Before you start the Adaptec CI/O Management Software, be sure that communication with the server via the network is already established. (See the documentation provided with your TCP/IP software for instructions on establishing communications, and also *Hints for Establishing Communications With Your Server* on page 7-3.)

Follow these steps to install the Adaptec CI/O Management Software for Novell NetWare:

- 1 Insert the Adaptec CI/O Management Software CD-ROM in your CD-ROM drive. If you are installing the software from diskettes, insert Disk 2 of the Adaptec CI/O Management Software for NetWare in the floppy disk drive.
- 2 From the NetWare colon prompt (:), type the following and press **Enter**:

```
load [pathname]nwsetup
```

(The `nwsetup` NLM is located at `\netware\disk2\nwsetup.nlm` on the CD-ROM, and at `nwsetup.nlm` on Disk 2 of the Adaptec CI/O Management Software for NetWare.)



Note: If you are using NetWare 3.12, you may receive a Failed to allocate resources error message at this point. This is because the CD-ROM (or floppy disk drive) is not part of the default search path. If this happens, you must add the CD-ROM or floppy disk drive to your search path by entering the following command before loading `nwsetup`:

```
search add [pathname]
```

- 3 From the NWSETUP Installation menu, select **Default Installation** or **Custom Installation** (press **F1** for help).
- 4 At the end of the installation process, select **Yes** when you are prompted to update the *autoexec.ncf* file. (This adds the appropriate NLM command lines to the file so that all software is automatically loaded when the server starts.)

See the *Adaptec CI/O Management Software User's Guide* for information on using the Adaptec CI/O Management Software to add, delete, or manage your arrays from your server console.

Adaptec CI/O Management Software Installation Hints

- For communications supported over TCP/IP, the *tcpip.nlm* must be loaded and the IP protocol must be bound to a valid IP address. The IP protocol generally needs to be bound to an ethernet frame type, *ETHERNET_II*, which must be specified when loading the LAN driver. A LAN driver can be loaded multiple times for different ethernet frame types.
- Command lines similar to the following are automatically added to the *autoexec.ncf* file when you run the *nwsetup* utility:

```
#  
# NWSETUP LAST UPDATE XX-XX-XX  
#  
RPCSTART  
IOMGR.NCF  
IOMGRSRV.NCF  
IOMGRRPC.NCF
```





Installing Software on a Remote Client

This chapter explains how to install the Adaptec CI/O Management Software on a remote network client running under Windows (Windows 3.1x, Windows[®] 95, and Windows NT). If you want the capability to manage your arrays on the server from a remote networked client, continue with the remainder of this chapter. Once installed, refer to the *Adaptec CI/O Management Software User's Guide* for instructions on using the software.

Installing Adaptec CI/O Management Software

Follow these steps to install the software:



Note: Before you start the Adaptec CI/O Management Software, be sure that communication with the server via the network is already established. As long as communication is established, it is not a requirement to log-on to the server to install the software and to monitor the server via the network. (See the documentation provided with your TCP/IP or SPX/IPX software for instructions on establishing communications, and also *Hints for Establishing Communications With Your Server* on page 7-3.)

- 1 Start Windows on the client.
- 2 Insert the Adaptec CI/O Management Software CD-ROM in your CD-ROM drive. If you are installing the software from diskettes, insert Disk 1 of the Adaptec CI/O Management Software for Windows 95 and Windows NT Clients.
- 3 Select **Run** from the File menu (Windows 95 and NT users select **Start**, and then **Run**), type the following and press **Enter**.

[pathname]setup.exe

(The *setup.exe* file is located in `\win_client\disk1\setup.exe` on the CD-ROM, and in `setup.exe` on Disk 1 of the Adaptec CI/O Management Software for Windows 95, and Windows NT Clients.)

- 4 Follow the directions that appear on the screen.

During installation you will be prompted to enter the host name of the client PC. If you do not know the host name, you can add the information later by inserting a line in the *autoexec.bat* file. Instructions for this step appear on the screen during installation.

See the *Adaptec CI/O Management Software User's Guide* for information on using the Adaptec CI/O Management Software to add, delete, or manage your arrays from the remote client.



Note: You must have the proper level of Adaptec CI/O Management Software password authorization if you want to add and delete arrays and spares from a networked client. The default password is “adaptec.” See the *Adaptec CI/O Management Software User’s Guide* for information on setting security options.

Hints for Establishing Communications With Your Server

Communication with the server via the network must be established prior to installing the Adaptec CI/O Management Software on a networked client. The following information is provided to help you set up proper communication:

TCP/IP Networks

- When installing your TCP/IP software (not provided by Adaptec), follow the installation instructions provided with your TCP/IP software. You will be asked to enter information such as IP address, host name, host file, etc.
- The TCP/IP stack uses the *host name* from TCP/IP setup.

SPX/IPX Networks

- On an SPX/IPX network, make sure to install the NetWare Client Software for Windows (provided by Microsoft). During installation, certain DLLs required by the Adaptec CI/O Management Software are installed.
- The *host name* is identified through the SET RPCHOST= environment variable. You can enter this variable through the setup process, or you can manually add it to the *autoexec.bat* file.



Note: Under dual stack situations, we recommend using the same *host name* for both TCP/IP and SPX/IPX to minimize any naming confusion.



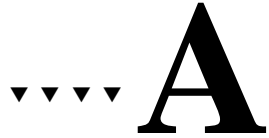

Configuring ARO-1130SA with the *SCSISelect* Utility

The *SCSISelect* configuration utility allows you to change SCSI settings without opening the server chassis or handling the card. *SCSISelect* also contains utilities that allow you to low-level format or verify the disk media of your SCSI hard disk drives.

The *SCSISelect* settings are listed in the table below. If you want to view and/or change the current settings, or if you would like to format or verify a disk, see *Starting the SCSISelect Utility* on page A-2. Detailed descriptions of each setting begin on page A-4.

SCSI Bus Interface Definitions
Host Adapter SCSI ID
SCSI Parity Checking
Host Adapter SCSI Termination
Host Adapter UltraSCSI
SCSI Device Configuration
Initiate Sync Negotiation
Maximum Transfer Rate
Enable Disconnection
Initiate Wide Negotiation ¹
Send Start Unit Command
Include in BIOS Scan
Additional Options
Array1000xA BIOS
BIOS Support for Bootable CD-ROM

¹ This option is available only if Wide SCSI is supported on the motherboard.

Starting the SCSISelect Utility

To start SCSISelect, press **Ctrl-A** when the following prompt appears when you turn on or reboot your server:

Press <Ctrl><A> for SCSISelect (TM) Utility!

The menu that appears displays the options Configure/View Host Adapter Settings and SCSI Disk Utilities, as shown in Figure 7-1.

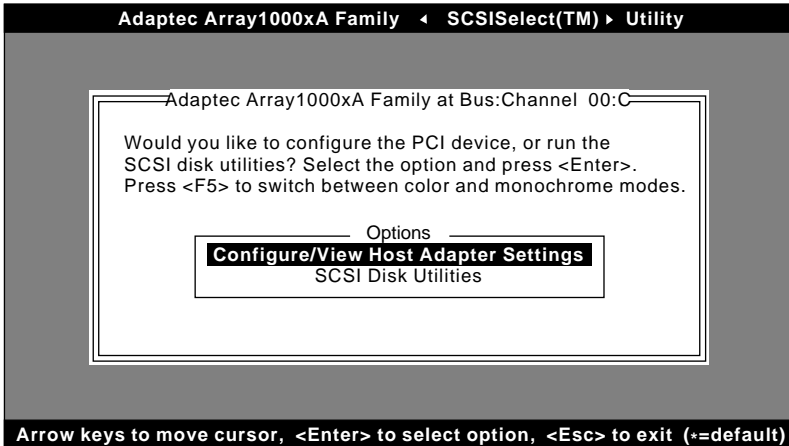

Figure 7-1. SCSISelect Menu

Using SCSISelect Menus

To select a SCSISelect menu option, move the cursor to the option with the **↑** and **↓** keys, then press **Enter**. In some cases, selecting an option displays another menu. You can return to the previous menu at any time by pressing **Esc**.

To restore the original SCSISelect default values, press **F6** from the Configure/View Host Adapter Settings screen. To toggle the display between color and monochrome modes, press **F5** from the main SCSISelect screen (this feature does not work on some monitors).

Exiting SCSISelect

To exit SCSISelect, press **Esc** until a message prompts you to exit (if you changed any host adapter settings, you are prompted to save the changes before you exit). Select **Yes** to exit, then press any key to reboot the workstation. Any changes you made in SCSISelect take effect after the server boots.

Using the SCSI Disk Utilities

To access the SCSI disk utilities, select the **SCSI Disk Utilities** option from the menu that appears after starting SCSISelect. Once the option is selected, SCSISelect immediately scans the SCSI bus (to determine the devices installed) and displays a list of all SCSI IDs and the devices assigned to each ID.

When you select a specific ID and device, a small menu appears, displaying the options **Format Disk** and **Verify Disk Media**.

- **Format Disk**—This utility allows you to perform a low-level format on a hard disk drive. Each hard disk drive must be low-level formatted before you can use your operating system's partitioning and file preparation utilities, such as MS-DOS *Fdisk* and *Format*.

Most SCSI disk devices are preformatted at the factory and do not need to be formatted again. The Adaptec Format Disk utility is compatible with the vast majority of SCSI disk drives.



Caution: A low-level format destroys all data on the drive. Be sure to back up your data before performing this operation. You *cannot* abort a low-level format once it is started.

- **Verify Disk Media**—This utility allows you to scan the media of a hard disk drive for defects. If the utility finds bad blocks on the media, it prompts you to reassign them; if you select *yes*, those blocks are no longer used. You can press **Esc** at any time to abort the utility.

SCSISelect Settings

SCSI Bus Interface Definitions

The following settings are the SCSISelect settings most likely to require any modification.

- **Host Adapter SCSI ID**— This option sets the ARO-1130SA's SCSI ID. We recommend that you leave the ARO-1130SA set to SCSI ID 7, which gives the ARO-1130SA the highest priority on the SCSI bus.
- **SCSI Parity Checking**—This option determines whether the ARO-1130SA verifies the accuracy of data transfer on the SCSI bus. You should disable SCSI Parity Checking on the ARO-1130SA and all SCSI devices if any SCSI device supported by the ARO-1130SA does not support SCSI parity; otherwise, leave it enabled. Most SCSI devices do support SCSI parity. If you are not sure whether a device supports SCSI parity, consult the documentation for the device.
- **Host Adapter SCSI Termination**—This option is used in conjunction with your motherboard termination settings. Refer to your motherboard documentation for instructions on properly setting termination.
- **Host Adapter UltraSCSI** —This option determines whether the ARO-1130SA supports Ultra SCSI data transfer speeds. If you have any Ultra SCSI devices installed, you should enable this setting. When this setting is enabled, the ARO-1130SA negotiates for data transfer speeds of up to 20 MBytes/sec (40 MBytes/sec for Wide SCSI devices).



Note: If you use Ultra SCSI data transfer speeds, be sure to use high-quality cables to connect the disk drives supported by the ARO-1130SA. The quality of the cable is much more critical when you use higher-speed data transfer.

SCSI Device Configuration

The SCSI device settings allow you to configure certain parameters for each device on the SCSI bus. To configure settings for a specific device, you must know the SCSI ID assigned to that device. If you are not sure of the SCSI ID, see *Using the SCSI Disk Utilities* on page A-3.

- **Initiate Sync Negotiation**—This option determines whether synchronous data transfer negotiation (Sync Negotiation) between the device and SCSI channel is initiated by the SCSI channel. Normally, you should leave Initiate Sync Negotiation set to *Enabled*, because most SCSI devices support synchronous negotiation and because it allows for faster data transfer.
- **Maximum Transfer Rate**—This option determines the maximum data transfer rate that the SCSI channel supports. The effective data transfer rate is doubled when Initiate Wide Negotiation is set to *Yes*. For example, a transfer rate of 20 MBytes/sec becomes 40 MBytes/sec.
- **Enable Disconnection**—This option determines whether the SCSI channel allows the SCSI device to disconnect from the SCSI bus (sometimes called Disconnect/Reconnect). This option should be enabled for maximum performance.
- **Initiate Wide Negotiation**—This option determines whether the SCSI channel attempts 16-bit data transfer instead of 8-bit data transfer. The effective data transfer rate is doubled when 16-bit data transfer is used. For example, a transfer rate of 10 MBytes/sec becomes 20 MBytes/sec. If you have a Wide SCSI device, make sure this option is enabled.
- **Send Start Unit Command**—This option determines whether the Start Unit Command is sent to the SCSI device at bootup (most devices do not require this).
- **Include in BIOS Scan**—This option determines whether the Array1000xA BIOS supports hard disk drives attached to the SCSI channel. When set to *Yes*, the ARO-1130SA BIOS controls the hard disk drive. When set to *No*, the ARO-1130SA BIOS does not control the hard disk drive.

Additional Options

Array1000xA BIOS

This option determines whether the ARO-1130SA BIOS is installed at boot time. When set to *Enabled*, the ARO-1130SA BIOS is installed and all Int13 (except bootable CD-ROM) devices are supported. When set to *Disabled*, the ARO-1130SA BIOS is not installed.

BIOS Support for Bootable CD-ROM

This option determines whether the Array1000xA BIOS supports booting from a CD-ROM drive. When set to *Enabled*, the ARO-1130SA allows booting from a CD-ROM drive.





Using the ARO-1130SA with Other Adaptec Products

You cannot install more than one ARO-1130SA card in the same system; however, you can install an ARO-1130SA in servers that have other PCI-, ISA-, or EISA-based host adapters installed. When installing multiple adapters, consider the following:

- Adaptec AAA-130xx Series adapters cannot coexist with an ARO-1130SA inside a RAIDport I or II equipped system.
- All drives in a single array must be connected to the same host adapter. A single array cannot be created with drives from two or more host adapters.
- If you are booting from a SCSI disk drive or array supported by the ARO-1130SA, then the ARO-1130SA must be the card that the server scans first. Some computers boot from the device with the lowest PCI device number; others boot from the device with the highest number. (See also *Making the Array Bootable* on page 4-5.) You can disable the BIOS on cards that are scanned before the desired boot card.
- In systems with EISA- and ISA-based host adapters, the boot host adapter must have the lowest BIOS base address. The system BIOS automatically controls the ARO-1130SA base address (the user has no control over the assigned address).

Using Driver Disk B

If the Array1000xA BIOS & Driver Selection Utility determines you require Disk A of the manager set driver diskettes, the rest of this appendix does not apply. If Disk B is required, then note the following for these Adaptec products:

- **AHA-294x, AHA-3940, or any other AIC-78x0 based host adapter:** These host adapters can coexist with an ARO-1130SA inside a RAIDport I or II system using Windows NT or NetWare. In Windows NT, however, it is necessary to make some modification to your Windows NT configuration. See *Using the ARO-1130SA with an AHA-294x, AHA-3940, or Other AIC-78x0 Based Host Adapter and Driver Disk B (Windows NT Only)* below.
- **AHA-3940AU/3940AUW:** Due to a PCI ID conflict with the hardware on the motherboard that requires driver Disk B, these host adapters *cannot* coexist with an ARO-1130SA inside a RAIDport I or II system.

Using the ARO-1130SA with an AHA-294x, AHA-3940, or Other AIC-78x0 Based Host Adapter and Driver Disk B (Windows NT Only)

This section offers two scenarios for using the ARO-1130SA in a system also containing any of the above host adapters. If the Array1000xA BIOS & Driver Selection Utility (see Chapter 3) determines you require Disk B of the manager set driver diskettes, follow the scenario below that matches your situation. You will need to install drivers and make changes to the Windows NT Registry.

If the Array1000xA BIOS & Driver Selection Utility determines you require Disk A, this section does not apply. To install the driver, follow the instructions in *Installing the Array1000xA Driver for Windows NT* on page 5-2.



Caution: We recommend that you do *not* attempt to change the Windows NT Registry unless you are an experienced computer user.

Scenario #1: Adding an ARO-1130SA to a RAIDport I or II System with an AHA-294x, AHA-3940, or Other AIC-78x0 Based Host Adapter

These instructions assume that Windows NT is *already installed* on the server and that the boot drive is currently connected to an AHA-294x, AHA-3940, or any other AIC-78x0 based host adapter. If the ARO-1130SA is already installed, shut down the server, remove the ARO-1130SA from the expansion slot, and restart the server.

Installing the ARO-1130SA Driver

- 1 Start the Windows NT Control Panel and double click the **SCSI Adapters** icon.
- 2 Click the **Drivers** tab and click **Add**.
- 3 Click **Have Disk ...**, and insert Disk B of the Array1000xA Family Manager Set diskettes in the floppy disk drive. (This diskette is included with your ARO-1130SA adapter.)
- 4 When the Install from Disk dialog box appears, type a:\winnt on the command line and click **OK**.
- 5 Select **Adaptec Array1000xA Family Adapter** and click **OK**.
- 6 When a message appears asking you if you want to restart Windows NT, click **No**.
- 7 Exit from Control Panel.

Changing Registry Settings

- 1 Back up the NT Registry, using one of the techniques described in *Backing up the Windows NT Registry* on page B-10



Caution: It is very important to back up the NT Registry before you make any changes to it. This allows you to restore the original NT Registry settings if there is a problem with the new configuration.

- 2 Run the Registry Editor (*regedit.exe*).

- 3 When the Registry Editor window appears, expand the tree on the left until you can see the nodes under `\HKEY_LOCAL_MACHINE\System\CurrentControlSet\Services`.
- 4 Select **cda1000** on the left part of the screen. Write down the cda1000 Tag value that appears on the right part of the screen.
The Tag value is a hex number followed by an equivalent decimal equivalent in brackets: for example, 0x00000002 [2].
- 5 Select **aic78xx** on the left part of the screen. Write down the aic78xx Tag value that appears on the right part of the screen.
- 6 Expand the tree on the left until you can see the nodes under `\HKEY_LOCAL_MACHINE\System\CurrentControlSet\Control\GroupOrderList`.
- 7 Select **GroupOrderList**.
- 8 Click the right mouse button on **SCSI Miniport** on the right side of the window and select **Modify** from the popup menu. A table appears with columns of two- and four-number groups, something like this:

```
0005 02 00 00 00 03 00 00 00
0010 01 00 00 00 01 01 00 00
0015 04 00 00 00 05 00 00 00
0020 06 00 00 00 07 00 00 00
etc.
```

This table of hexadecimal numbers indicates the Tag-value sequence in which the SCSI Miniport drivers are loaded when you start Windows NT.

- 9 Determine what the Tag value loading sequence is. Here is how you do this:
 - a Ignore the four-digit groups on the left of each row.
 - b Going from left to right, and starting on the first row, divide the two-digit numbers into groups of eight. In this example, the groups are

```
02 00 00 00
03 00 00 00
01 00 00 00
```

01 01 00 00

etc.

You need to write down *all* the number groups from all rows in the table.

- c** In each group of eight numbers, reverse the sequence of the two-digit pairs, like this:

00 00 00 02

00 00 00 03

00 00 00 01

00 00 01 01

etc.

- d** Write down the series of resulting numbers, without all the extra zeroes. In this example, it is 2, 3, 1, 101, etc. This is the Tag value loading sequence for SCSI Miniport drivers. In other words, when Windows NT loads these miniport drivers, the one with Tag value 2 is loaded first, then the one with Tag value 3, and so on.
- 10** Compare the Tag value loading sequence to the actual tag values of cda1000 and aic78xx that you determined in steps 4 and 5. If cda1000 is loading before aic78xx, skip to step 16. If aic78xx is loading first, continue with the next step.
 - 11** Expand the tree on the left until you can see the nodes under \HKEY_LOCAL_MACHINE\System\CurrentControlSet\Services.
 - 12** Select **cda1000** on the left part of the screen. Click the right mouse button on **Tag Value** on the right part of the screen and select **Modify** from the popup menu.
 - 13** Type the tag value of the aic78xx miniport driver in the space provided and click **OK**.
 - 14** Select **aic78xx** on the left part of the screen. Click the right mouse button on **Tag Value** on the right part of the screen and select **Modify** from the popup menu.
 - 15** Type the tag value of the cda1000 miniport driver in the space provided and click **OK**. You have now reversed the tag values for the two miniport drivers, and the cda1000 driver will load first.

- 16** Exit from the Registry Editor and from Windows NT. Then shut down the server.
- 17** Physically install the ARO-1130SA in the PCI/RAIDport expansion slot.
- 18** Attach your boot drive to one of the SCSI channels controlled by the ARO-1130SA and boot the server.

Scenario #2: Adding an AHA-294x, AHA-3940, or Other AIC-78x0 Based Host Adapter to a RAIDport I or II System with an ARO-1130SA

These instructions assume that Windows NT is *already installed* on the server and that the boot drive is connected to the SCSI channel controlled by the ARO-1130SA. If the AHA-294x, AHA-3940, or any other AIC-78x0 based host adapter is already installed, shut down the server, remove the adapter from the slot, and restart the system.

Installing the AHA-2940, AHA-3940, or AIC-78x0 Family Driver

- 1** Start the Windows NT Control Panel and double click the **SCSI Adapters** icon.
- 2** Click the **Drivers** tab and click **Add**.
- 3** Click **Have Disk ...**, and insert AIC-78xx Family Manager Set diskette in the floppy disk drive. (This diskette was included with your 2940 Family adapter.)
- 4** When the Install From Disk dialog box appears, type `a:\winnt\4_0` on the command line and click **OK**.
- 5** Select **Adaptec AHA290x/291x/394x/494x/4944/AIC78xx PCI SCSI Controller (NT 4.0)** and click **OK**.
- 6** When a message appears asking if you want to restart Windows NT, click **No**.
- 7** Exit from Control Panel.

Changing Registry Settings

- 1 Back up the NT Registry, using one of the techniques described in *Backing up the Windows NT Registry* on page B-10



Caution: It is very important to back up the NT Registry before you make any changes to it. This allows you to restore the original NT Registry settings if there is a problem with the new configuration.

- 2 Run the Registry Editor (*regedit.exe*).
- 3 When the Registry Editor window appears, expand the tree on the left until you can see the nodes under `\HKEY_LOCAL_MACHINE\System\CurrentControlSet\Services`.
- 4 Select **cda1000** on the left part of the screen. Write down the cda1000 Tag value that appears on the right part of the screen.
The Tag value is a hex number followed by an equivalent decimal equivalent in brackets: for example, 0x00000002 [2].
- 5 Select **aic78xx** on the left part of the screen. Write down the aic78xx Tag value that appears on the right part of the screen.
- 6 Expand the tree on the left until you can see the nodes under `\HKEY_LOCAL_MACHINE\System\CurrentControlSet\Control\GroupOrderList`.
- 7 Select **GroupOrderList**.

- 8** Click the right mouse button on **SCSI Miniport** on the right side of the window and select **Modify** from the popup menu. A table appears with columns of two- and four-number groups, something like this:

```
0005 02 00 00 00 03 00 00 00
0010 01 00 00 00 01 01 00 00
0015 04 00 00 00 05 00 00 00
0020 06 00 00 00 07 00 00 00
etc.
```

This table of hexadecimal numbers indicates the Tag-value sequence in which the SCSI Miniport drivers are loaded when you start Windows NT.

- 9** Determine what the Tag value loading sequence is. Here is how you do this:

- a** Ignore the four-digit groups on the left of each row.
- b** Going from left to right, and starting on the first row, divide the two-digit numbers into groups of eight. In this example, the groups are

```
02 00 00 00
03 00 00 00
01 00 00 00
01 01 00 00
etc.
```

You need to write down *all* the number groups in all rows of the table.

- c** In each group of eight numbers, reverse the sequence of the two-digit pairs, like this:

```
00 00 00 02
00 00 00 03
00 00 00 01
00 00 01 01
etc.
```

- d** Write down the series of resulting numbers, without all the extra zeroes. In this example, it is 2, 3, 1, 101, etc. This is the Tag value loading sequence for SCSI Miniport drivers. In other words, when Windows NT loads these miniport drivers, the one with Tag value 2 is loaded first, then the one with Tag value 3, and so on.
- 10** Compare the Tag value loading sequence to the actual tag values of cda1000 and aic78xx that you determined in steps 4 and 5. If cda1000 is loading before aic78xx, skip to step 16. If aic78xx is loading first, continue with the next step.
- 11** Expand the tree on the left until you can see the nodes under `\HKEY_LOCAL_MACHINE\System\CurrentControlSet\Services`.
- 12** Select **cda1000** on the left part of the screen. Click the right mouse button on **Tag Value** on the right part of the screen and select **Modify** from the popup menu.
- 13** Type the tag value of the aic78xx miniport driver in the space provided and click **OK**.
- 14** Select **aic78xx** on the left part of the screen. Click the right mouse button on **Tag Value** on the right part of the screen and select **Modify** from the popup menu.
- 15** Type the tag value of the cda1000 miniport driver in the space provided and click **OK**. You have now reversed the tag values for the two miniport drivers, and the cda1000 driver will load first.
- 16** Exit from the Registry Editor and from Windows NT. Then shut down the server.
- 17** Physically install the AHA-2940 Family adapter in the expansion slot.
- 18** Boot the server.

Backing up the Windows NT Registry

It is very important to back up the Windows NT Registry before making any changes to it. This will allow you to recover if the changes make your system unusable. Here are two ways to back up the Windows NT Registry. The backup utilities described here are included with NT Workstation:

- Use the *ntbackup* utility to create a tape copy of all data files and Registry information. Be sure to select the **Backup Local Registry** option when performing the backup.
- Run the *rdisk* utility with the */s* option to create a copy of the Registry on a hard disk. (A typical backup file is 5 MBytes to 10 MBytes in size.) Then use *xcopy* or some other command to copy the information to removable media. You must have the three NT boot floppy disks to restore an RDISK-saved registry to your workstation.



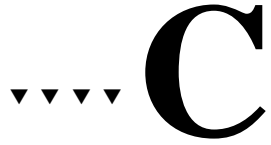

Troubleshooting

Troubleshooting Checklist

Check the following if you have problems installing or running the ARO-1130SA and SCSI devices:

- Does the ARO-1130SA BIOS sign-on message appear during bootup? If not, check the following items:
 - Is the ARO-1130SA properly seated in a PCI/RAID*port* expansion slot? Refer to your computer documentation for the slot location.
 - Does your computer CMOS setup require you to enable PCI bus parameters (see your computer documentation)? If so, run the CMOS Setup program and assign the parameters—usually IRQ, Enable PCI Slot, and Enable Master.
 - Have you run the Array1000xA BIOS & Driver Selection Utility?
- Is the SCSI bus terminated properly, and are all SCSI devices turned on?
- Are all SCSI bus cables and power cables connected?
- Does each channel and each device on the channel have a unique SCSI ID?
- If you are having trouble booting from a SCSI disk drive or array, make sure your computer's CMOS setup is set to **No Drives Installed** (the required setting for SCSI drives). Also, verify that the drive or array has been selected as the boot-first (boot) device and that the boot partition is active.

Problems Running the Software On Your Windows NT Server

If the Adaptec CI/O Management Software does not start when you double-click the program icon and you see a warning box with Unable to Initialize IOMAPI, try the following:

- Verify that the following NT services have a status of *Started* (double-click the **Services** icon in Control Panel). If they do not, select each service and press the **Start** button:

- CIO Array Management Service
- CIOArrayManager RPC Command
- CIOArrayManager RPC EventP
- CIOArrayManager RPC Event
- NobleNet Portmapper

- Make sure you have the proper security access rights to the Windows NT Services. The Windows NT Services can be started, stopped, paused, etc., by different users (administrators, power users, local users, etc.) according to the NT service security rules defined by Microsoft (refer to the Windows NT documentation for more details).
- Verify that the Registry was updated correctly during installation. If the values do not match the values listed below, try reinstalling the Adaptec CI/O Management Software:

- The correct entries for *HKEY_LOCAL_MACHINE\SYSTEM\CurrentControlSet\Services\CIOArrayManagement* are:

- DisplayName: REG_SZ: CIO Array Management Service (v x.xx)
- ErrorControl: REG_DWORD: 0x01
- ImagePath: REG_SZ: [*Pathname specified during installation*]\iomgr.exe
- ObjectName: REG_SZ: LocalSystem
- Start: REG_DWORD: 0x02
- Type: REG_DWORD: 0x110
- SharedMemName: REG_SZ: iomgr.shm

- The correct entries for *HKEY_LOCAL_MACHINE\SYSTEM\CurrentControlSet\Services\EventLog\System\CIOArrayManagement* are:
 - EventMessageFile: REG_SZ: [*pathname to system32 directory*]\system32\iomgrmsg.dll
 - TypesSupported: REG_DWORD: 0x7
- The correct entries for *HKEY_LOCAL_MACHINE\SYSTEM\CurrentControlSet\Services\NobleNetPortmapper* are:
 - DisplayName: REG_SZ: NobleNet Portmapper
 - ErrorControl: REG_DWORD: 0x1
 - ImagePath: REG_EXPAND_SZ: Absolute Path of “portserv.exe”
 - ObjectName: REG_SZ : LocalSystem
 - Start: REG_DWORD : 0x02
 - Type: REG_DWORD : 0x10
- The correct entries for *HKEY_LOCAL_MACHINE\SYSTEM\CurrentControlSet\Services\CIOArrayManager RPC Command* are:
 - DependOnService: REG_MULTI_SZ: NobleNet Portmapper CIOArrayManagement
 - DisplayName: REG_SZ: CIOArrayManager RPC Command
 - ErrorControl: REG_DWORD: 0x1
 - ImagePath: REG_EXPAND_SZ: Absolute Path of “iomrpccm.exe”
 - ObjectName: REG_SZ : LocalSystem
 - Start: REG_DWORD : 0x02
 - Type: REG_DWORD : 0x10

- The correct entries for *HKEY_LOCAL_MACHINE\SYSTEM\CurrentControlSet\Services\CIOArrayManager RPC Event* are:

DependOnService: REG_MULTI_SZ: CIOArrayManagement CIOArrayManager RPC Command
DisplayName: REG_SZ: CIOArrayManager RPC Event
ErrorControl: REG_DWORD: 0x1
ImagePath: REG_EXPAND_SZ: Absolute Path of "iomrpcev.exe"
ObjectName: REG_SZ : LocalSystem
Start: REG_DWORD : 0x02
Type: REG_DWORD : 0x10

Problems Running SNMP Agent on Your Windows NT Server

If you have problems running SNMP agent, try the following:

- Make sure you configure Windows NT base SNMP support, including the appropriate trap community name and trap destinations. The SNMP configuration is accessed via Control Panel/Network/SNMP Service. If the SNMP service does not appear as a configurable item, then SNMP support must be installed from the Windows NT distribution media.
- Verify that the values in the Registry match the values listed below:
 - Make sure *HKEY_LOCAL_MACHINE\SYSTEM\CurrentControlSet\Services\SNMP\Parameter\ExtensionAgents* includes an entry like this:

```
3 REG_SZ SOFTWARE\Adaptecl\CIOSNMP\CurrentVersion
```

(where 3 should be replaced by the next unused number)

- Make sure *HKEY_LOCAL_MACHINE\SOFTWARE\Adpatec\CIOSNMP\CurrentVersion* includes a value like this:

Pathname: REG_SZ: [installationpath]\ciosnmp.dll

For example, if the recommended *c:\ciodata* path is used for the installation directory, then the Pathname value would look like:

Pathname: REG_SZ: c:\ciodata\ciosnmp.dll

- Make sure *HKEY_LOCAL_MACHINE\SYSTEM\CurrentControlSet\Services\SNMP* includes an entry like this:

DependOnService: REG_MULTI_SZ: CIOArrayManagement



Using a CD-ROM Drive

Should you need to install a CD-ROM, the Array1000xA Family Manager Set drivers diskette included with the ARO-1130SA contains the DOS and NetWare driver software you need in order to use a CD-ROM controlled by the ARO-1130SA. This appendix explains how to set up your CD-ROM drive so that you can initially install your software.

Using a CD-ROM Drive with DOS

To operate a CD-ROM drive supported by the ARO-1130SA under DOS, you need

- The SCSI driver, *aspi8dos.sys* (version 1.32 or later)
- The CD-ROM driver, *aspicd.sys*
- The Microsoft CD-ROM extensions, *mscdex.exe*

The *aspi8dos.sys* and *aspicd.sys* files must be copied from the `ldos` directory on the Adaptec Array 1000xA Family Manager Set driver diskette to a directory (e.g., `c:\scsi`) on your hard disk drive. The *mscdex.exe* file is included with MS-DOS 6.x and above (see your MS-DOS documentation for details).



Note: If you use MS-DOS 5 and do not have *mscdex.exe*, we recommend that you upgrade to MS-DOS 6 or above. You can also obtain *mscdex.exe* from Microsoft's online bulletin board or the CompuServe forum.

To complete the driver installation, edit the *config.sys* file to include command lines for *aspi8dos.sys* and *aspicd.sys*, and edit the *autoexec.bat* file to include a command line for *mscdex.exe*. The following examples illustrate the command line format and the command options appropriate for most systems.

- Sample command lines for *config.sys* file:

```
device=c:\scsi\aspi8dos.sys /d  
device=c:\scsi\aspicd.sys /d:aspicd0
```

- Sample command line for *autoexec.bat* file:

```
\dos\mscdex.exe /d:aspicd0 /M:12
```

(This assigns the CD-ROM the next available drive letter, typically *D* if there is only one DOS drive.)

The following tables describe the *aspi8dos* and *aspicd* command line options. For a description of *mscdex* command line options, see your Microsoft DOS documentation. You can type command line options in uppercase or lowercase letters. Leave a blank space between options.

Command Line Options for *aspi8dos.sys*

Option	Example	Use
<i>/ccbs<count></i>	<i>/ccbs8</i>	Specifies the maximum number of concurrent ASPI commands that can be supported. The valid range is 1 through 16. The default is 4. If you increase this value, the size of the ASPI manager also increases. Use this option only if you want to run an ASPI program that specifies a higher number of concurrent commands.
<i>/d</i>	<i>/d</i>	Displays information about the ARO-1130SA and attached SCSI devices when the computer boots.
<i>/L</i>	<i>/L</i>	Enables <i>aspi8dos</i> to recognize all eight possible LUNs associated with each SCSI ID. If the option is not used, <i>aspi8dos</i> can recognize only LUN 0 for each SCSI ID.
<i>/mn</i>	<i>/m1</i>	Causes <i>aspi8dos</i> to scan the PCI bus. The method used to scan the bus is determined by the value of <i>n</i> : <i>/mb</i> = scan PCI bus using PCI BIOS calls <i>/m1</i> = scan PCI bus using Mechanism #1 <i>/m2</i> = scan PCI bus using Mechanism #2 <i>aspi8dos</i> automatically scans the PCI bus for SCSI devices. It tries to determine which scanning method will work best for the given system configuration. Use the <i>/mb</i> , <i>/m1</i> , and <i>/m2</i> options only if you want to override the <i>aspi8dos</i> internal scanning mechanism. Usually <i>aspi8dos</i> can determine which scanning method is optimal for your system. (PCI BIOS calls are described in the PCI BIOS spec; scanning mechanisms #1 and #2 are described in the PCI spec.
<i>/norst</i>	<i>/norst</i>	Prevents <i>aspi8dos</i> from resetting the SCSI bus when you boot your computer. By default, <i>aspi8dos</i> resets the SCSI bus when you boot the computer if the host adapter BIOS is not present. You can use <i>/norst</i> to prevent this from happening.
<i>/pause</i>	<i>/pause</i>	Pauses the system after loading <i>aspi8dos</i> at bootup, so you can read the message on the screen. After you read the message, press any key to resume booting.
<i>/rst</i>	<i>/rst</i>	Forces <i>aspi8dos</i> to reset the SCSI bus when you boot your computer. By default, <i>aspi8dos</i> does not reset the SCSI bus when you boot your computer if the host adapter BIOS is present.
<i>/s<slot number></i>	<i>/s1 /s3</i>	Indicates the slot number(s) where you want <i>aspi8dos</i> to look for host adapters. Valid slot numbers = 1 to 15. If you do not use this option, <i>aspi8dos</i> scans all slots for host adapters, beginning at slot 1.

Command Line Options for *aspcd.sys*

Option	Example	Use
<i>/d:<name></i>	<i>/d:aspcd0</i>	Required in the <i>config.sys</i> command line. Assigns a name to the CD-ROM drive so that <i>mscdex</i> can assign the CD-ROM a logical drive letter. The name must exactly match the CD-ROM drive name in the <i>mscdex</i> command line in <i>autoexec.bat</i> . Use any eight-character name.
<i>/id={...}</i>	<i>/id=2+4</i> <i>/id=3+5+1:4</i>	Specifies CD-ROM drives controlled by <i>aspcd</i> . By default, <i>aspcd</i> controls all drives. In the first example, which is for a computer with one host adapter, <i>aspcd</i> controls the devices with SCSI IDs 2 and 4. In the second example, for a computer with two host adapters, <i>aspcd</i> controls the devices with SCSI IDs 3 and 5 on host adapter 0 and SCSI ID 4 on host adapter 1 (if you do not specify the host adapter number, <i>aspcd</i> assumes it is 0).
<i>/L</i>	<i>/L</i>	Enables <i>aspcd</i> to recognize all eight possible LUNs associated with each SCSI ID. If the option is not used, <i>aspcd</i> can recognize only LUN 0 for each SCSI ID. Add the <i>/L</i> option to the command line if you have a CD-ROM drive that can access multiple discs. If your computer system includes a Pioneer DRM-600 or DRM-604x multiple-disc CD-ROM drive, you do not need to add the <i>/L</i> option. The <i>aspcd</i> device driver automatically scans multiple LUNs if it detects one of these devices on the SCSI bus.
<i>/norst</i>	<i>/norst</i>	Prevents <i>aspcd</i> from issuing a SCSI Bus Reset message at system start-up. The default is to issue it. The SCSI Bus Reset message (supported by Toshiba, Hitachi, and NEC drives) resets drives that are playing audio CDs when the computer reboots.
<i>/pause</i>	<i>/pause</i>	Makes your system pause after loading <i>aspcd</i> at bootup, so you can read the message on the screen. Press any key to resume booting.
<i>/type:<drive vendor></i>	<i>/type:sony</i>	Allows <i>aspcd</i> to support audio play mode for CD-ROM drives that are compatible with a supported drive type but are not included on the list of supported drives. If you use the <i>/type:<drive vendor></i> option, <i>aspcd</i> assumes that all CD-ROM drives on the SCSI bus are made by this vendor—you cannot combine different brands of CD-ROM drives on the bus. The valid entries for this option are chinon, denon, hitachi, lms, nec, panasonic, sony, texel, and toshiba.

Using a CD-ROM Drive with NetWare

To operate a CD-ROM drive connected to the ARO-1130SA under NetWare, you need the *aspcd.dsk* driver. The driver must be copied from the \dos directory on the Array1000xA Family Manager Set driver diskette to a directory on your hard disk drive.

Follow these steps to set up the CD-ROM drive under NetWare:

- 1 At the server prompt, enter

```
load install
```
- 2 From the Installation Options menu, select **Available System Options** and then **Edit STARTUP.NCF**.
- 3 Insert the following lines:

```
load [pathname]aspcd.dsk
load cdrom.nlm
```
- 4 Press the **Esc** key, save the changes, and exit *install.nlm*.
- 5 Down the server normally and restart.



Note: To access your CD-ROM without restarting your server, simply enter each of the command lines listed in Step 3 at the server prompt (:); then proceed to Step 6.

- 6 At the server prompt, enter

```
cd device list
```

A list of CD-ROM drives appears.
- 7 Write down the device number and volume name of the CD-ROM.
- 8 At the server prompt, enter

```
cd mount <x> <name>
```

where *<x>* is the device number and *<name>* is the volume name you wrote down in step 5.





Using the SNMP Agent

This appendix provides information on using the SNMP agent for NetWare and Windows NT. A section describing how to load MIBs in the MIB database is also provided.

NetWare

- 1 Modify the *traptarg.cfg* file which specifies SNMP trap destinations.
 - a Open the *traptarg.cfg* (*sys:\etc\traptarg.cfg*) file using any editor.
 - b Scroll down to the Protocol IPX section of the file.
 - c For each client PC which is to receive traps using the IPX network protocol, add a line to the file that includes the IPX network number (8 digits) and the MAC address (12 digits) of the client PC. Include a tab character before the IPX Network Number. For example:

(Tab)00000002:008DAD088E24

When all of the appropriate entries are added, the Protocol IPX section should look something like the following.

```
Protocol IPX
00000002:008DAD088E24
00000002:0080AD0761EC
```

2 Similar to instructions for the Protocol IPX section, edit the *traptarg.cfg* file to specify IP addresses mapped to MAC addresses for each client PC which is to receive traps using the TCP/IP network protocol.

3 Start the SNMP agent

a Load the SNMP agent by entering the following command:

```
load cio20 [c<string>] [v]
```

b The optional parameters are:

```
c<string>
```

Load the agent using the SNMP community name contained in <string>. The default SNMP community name is "public".

v

Load the agent in verbose mode, which will cause debugging information to be sent to the console.



Note: The I/O Manager must be loaded prior to loading the SNMP agent.

Windows NT

The SNMP agent is automatically installed when you install Adaptec CI/O Management Software.

There are no command line options for the CI/O SNMP agent; however, if a file named *ciosnmp.vb* is placed in the I/O Manager installation directory, the CI/O SNMP agent will write a debugging trail to a file named *ciosnmp.log* in the same directory. It does not matter what the contents of the *ciosnmp.vb* file are. The log file will be overwritten each time the NT SNMP agent is restarted. If you have problems running the SNMP agent, refer to *Problems Running SNMP Agent on Your Windows NT Server* on page C-4.



Note: The I/O Manager must be loaded prior to loading the SNMP agent.

Loading MIBs in the MIB Database

Follow the procedure below to load MIBs in the MIB database while running HP OpenView. For more complete information refer to the *Managing MIB Data* section of the HP OpenView Manual.

- 1 Select the **Options:Load/Upload MIBs:SNMP** menu item, the **MIB Load/Upload MIBs:SNMP** dialog box appears, listing the MIBs currently loaded.
- 2 Click the **Load** button. The Load MIB from File dialog box appears, listing the files in the default directory.
- 3 Browse the CI/O Setup Diskette and double-click the MIB file you want to load. The MIB is automatically loaded and the MIB Load/Unload MIBs dialog box reappears, showing the list of currently loaded MIBs.
- 4 The MIB name is now included in the Loaded MIBs scrollable list.

If a MIB does not load properly, you will receive an error message. The problem could be one of the following:

- A syntax error in the MIB. The MIB loader error message contains the MIB where the error is occurring.
- The vendor's MIB. For example, the vendor's MIB might not match the version for the device that is on the network.

- 5 Click **Close** to exit this operation.



▼▼▼▼ Index

A

- AAA-130xx Series adapters B-1
- Adaptec CI/O management software 1-3, 5-5, 6-1, 6-7, 6-8, 7-2
- AHA-2940 family
 - driver B-6
- ARO-1130SA
 - BIOS address B-1
 - board layout 2-2
 - components 2-2
 - driver B-3
 - installation 2-4
 - system requirements 1-2
 - using with AHA-2940 adapter B-3

Array

- booting from 4-5, C-1
- creating 4-2-4-4
- Array1000xA BIOS & Driver Selection Utility 1-1, 1-3, 2-1, 3-1, 5-1
- ArrayConfigSA 1-3, 4-1-4-4
- aspi8dos.sys* D-3
- aspicd.sys* D-2
- aspitran.dsk* 6-4, 6-5
- autoexec.bat* 7-2, 7-3
- autoexec.ncf* 6-8

B

- BIOS
 - address B-1
 - Array1000 A-1
 - bios and driver selection utility 3-1

- display checksum 3-2
- EPROM 2-2
- erase 3-3
- save to a file 3-3
- scan A-1, A-5
- sign-on message C-1
- Block size 4-4
- Board layout 2-2
- Boot partition C-1
- Bootable CD-ROM 5-3
- Booting
 - from an array 4-5, C-1
- Bus contacts 2-2
- Bus parameters C-1

C

- Cables
 - See SCSI Cables
- cda1000.sys* 5-2
- CD-ROM drive
 - install Windows NT 5-3
 - using under DOS D-1
 - using under NetWare D-5
- Channels 2-5
- Client machine 7-1, 7-2
- CMOS setup C-1
- Communications module 6-6
- Communications with the server 7-3
- Components 2-2
- Customer support iii

D

- DIMM 1-2, 2-2, 2-3

Disconnection A-1, A-5

DLLs 7-3

Drivers

for DOS D-1

for NetWare 6-2, D-5

for Windows NT 5-2

E

Enable disconnection A-1, A-5

Establishing communications 7-3

Ethernet frame types 6-8

Expansion slot 2-2, 2-4, C-1

F

Format disk 4-4, A-3

H

Hardware installation 1-3

Host adapter SCSI ID A-1

Host file 7-3

Host name 7-3

I

ID numbers A-4, C-1

IDE drives 2-5

Include in BIOS scan A-5

Initialize mode 4-4

Initiate sync negotiation A-1, A-5

Initiate wide negotiation A-1, A-5

Installation

Adaptec CI/O management
software 5-5, 6-7, 6-8, 7-2

ARO-1130SA 2-4

memory 2-3

NetWare driver 6-2-6-5

NetWare software 6-1-6-8

overview 1-3, 2-1

software on remote client 7-1, 7-2

Windows NT driver 5-2-5-4

Windows NT software 5-1-5-6

IP address 6-8, 7-3

IRQ C-1

L

LAN driver 6-8

LED connector 2-2, 2-5

Load command 6-4

Low-level format 4-4

LUNs D-3, D-4

M

Manager set diskettes 2-1, 3-1, 5-1,
5-3, 5-4, 6-1

Memory 2-3

MIBs E-3

Microsoft CD-ROM extensions D-1
mcsd.exe D-1

N

NetWare 6-1-6-8

aspiran.dsk 6-4

cda1000.dsk 6-5

client software 7-3

load command 6-4

SNMP agent E-1

startup.ncf 6-4

NT services 5-5, C-2

P

Parameters C-1

Parity checking A-4

Password authorization 5-6, 7-3

PCI bus

expansion slot 2-4

parameters C-1

R

RAID 0 4-2

RAID 0/1 4-2
 RAID 1 4-2
 RAID 5 4-2
 Registry B-3
 Remote client 7-1, 7-2
 Requirements, system 1-2
 RPCSTART 6-8

S

SCSI
 cables C-1
 channels 2-5
 ID numbers A-4, C-1
 parity checking A-4
 terminators A-1, A-4, C-1
 SCSI parity checking A-1
 SCSI*Select* Utility 2-6, A-1–A-5
 Send start unit command A-1, A-5
 Server communications 7-3
 Services 5-5, C-2
 SNMP agent C-4, E-1–E-3
 Spare disks 4-3
 SPX/IPX 7-2, 7-3
 Stacks 7-3
startup.ncf 6-4
 Synchronous negotiation A-1, A-5
 Synchronous transfer rate A-1, A-5
 System requirements 1-2

T

TCP/IP 6-8, 7-2, 7-3
tcpip.nlm 6-8
 Termination A-1, A-4, C-1
 TIRPC communications module 6-6
 Transfer rates A-1, A-5
 Troubleshooting C-1–C-5

U

Ultra SCSI A-1, A-4

V

Verify disk media A-3

W

Wide negotiation A-1, A-5
 Windows NT 5-1–5-6
 driver installation 5-2–5-4
 registry B-3, B-10
 services 5-5, C-2
 SNMP agent E-2



