

COVER FOR PREPRINTED SHELL 511589-00

USER'S GUIDE

ADAPTEC CI/O MANAGEMENT SOFTWARE



Adaptec, Inc.
691 South Milpitas Boulevard
Milpitas, CA 95035

© 1998 Adaptec, Inc.
All rights reserved. Adaptec, and the Adaptec logo are
trademarks of Adaptec, Inc. which may be registered in
some jurisdictions.

Printed in Singapore
STOCK NO.: 511896-00, Rev. B KL 6/98

▼▼▼▼ Adaptec CI/O Management
Software

User's Guide

 **adaptec®**

Copyright

© 1998 Adaptec, Inc. All rights reserved. No part of this publication may be reproduced, stored in a retrieval system, or transmitted in any form or by any means, electronic, mechanical, photocopying, recording or otherwise, without the prior written consent of Adaptec, Inc., 691 South Milpitas Blvd., Milpitas, CA 95035.

Trademarks

Adaptec, the Adaptec logo, AHA, Array1000, ArrayConfig, Adaptec CI/O, and EZ-SCSI are trademarks of Adaptec, Inc. which may be registered in some jurisdictions.

Windows and Windows 95 are registered trademarks and Windows NT is a trademark of Microsoft Corporation in the U.S. and other countries used under license.

All other trademarks are owned by their respective owners.

Changes

The material in this document is for information only and is subject to change without notice. While reasonable efforts have been made in the preparation of this document to assure its accuracy, Adaptec, Inc. assumes no liability resulting from errors or omissions in this document, or from the use of the information contained herein.

Adaptec reserves the right to make changes in the product design without reservation and without notification to its users.

Adaptec Technical Support and Services

If you have questions about installing or using your Adaptec product, check this user's guide first—you will find answers to most of your questions here. If you need further assistance, please contact us. We offer the following support and information services:

Electronic Support

Technical information, including product literature, answers to commonly asked questions, information on software upgrades and other topics is available electronically through the following:

- Adaptec World Wide Web (WWW) site at <http://www.adaptec.com>
- File Transfer Protocol (FTP) server at <ftp.adaptec.com>.
- Adaptec USA Bulletin Board Service (BBS) at 408-945-7727; supports up to 28,800 bps (bits per second), 8 data bits, 1 stop bit, no parity. No product literature is available on the Adaptec BBS.
- Interactive Fax System at 303-684-3400; available 24 hours a day, 7 days a week.
- To submit your electronic mail message to Adaptec Technical Support, use the product support information Webmail form at <http://www.adaptec.com/support/webmail.html>

Technical and Product Support

- For technical support and information about many of Adaptec's electronic support services, call 800-959-7274 or 408-945-2550, 24 hours a day, 7 days a week.
- To use the Adaptec Interactive Support System, call 800-959-7274 or 408-945-2550, 24 hours a day, 7 days a week. The system prompts you with questions regarding your problem and then provides step-by-step troubleshooting instructions.
- To speak with a product support representative, call 408-934-7274, M-F, 6:00 A.M. to 5:00 P.M., Pacific Time. After hours, on weekends, and on holidays, product support is also available for a fee at 800-416-8066.

Sales and Ordering Information

- For sales information, call 800-959-7274 or 408-945-2550, M-F, 6:00 A.M. to 5:00 P.M., Pacific Time.
- To order Adaptec software and SCSI cables, call 800-442-7274 or 408-957-7274, M-F, 6:00 A.M. to 5:00 P.M., Pacific Time.
- To request additional documentation for Adaptec products, call 800-934-2766 or 510-732-3829, M-F, 6:00 A.M. to 5:00 P.M., Pacific Time.

|

—

|

—

—

|

|

—

▼▼▼▼ Contents

1 Getting Started

Using the Adaptec CI/O Management Software 1-2
Conventions 1-3

2 Entering and Viewing Server Information

Entering and Viewing Server Information 2-1
 Adding a New Server Address 2-1
 Viewing and Editing Server Information 2-4
 Deleting a Server Address 2-6
 Viewing a List of Current Server Events 2-6
 Changing Filter Options 2-9
 Choosing Notification Settings 2-10
 Viewing Historical Server Information 2-11
Interpreting and Responding to Server Event Messages 2-12
Entering and Viewing Preference Information 2-13
 Editing the Permanent List 2-14

3 Viewing SCSI Device Information

Viewing Arrays from an External RAID Controller 3-2
Viewing the SCSI Information Dialog Box 3-4
Viewing SCSI Adapter Information 3-5
Viewing SCSI Channel Information 3-6
Rescan 3-7
 Rescan Details 3-7
Managing SCSI Adapters 3-8

4 Configuring Arrays and Spares

- Starting the Program 4-2
- Creating an Array 4-4
 - Setting Advanced Array Options 4-9
- Making an Array the First Virtual Device 4-10
- Deleting an Array 4-12
- Initializing an Array 4-13
- Creating Dedicated Spares or a Spare Pool 4-15
- Deleting a Spare 4-18
- Managing Arrays on External RAID Controllers 4-19

5 Viewing Array and Device Information

- Viewing Array Information 5-2
- Viewing Spare Information 5-4
- Viewing SCSI Device Information from an Array Controller 5-5
- Rescanning the Server 5-5
- Viewing Array Controller Information 5-7
- Viewing Channel Information 5-9

6 Performing Array, Spare, and Disk Operations

- Performing Array Operations 6-2
 - Reconstructing an Array 6-2
 - Pausing I/O on an Array 6-5
 - Verifying Array Integrity 6-7
 - Blinking Array Drive Lights 6-9
 - Reactivating an Off-line Array 6-10
 - Changing an Array Name 6-11
 - Forcing a Spare 6-11
- Performing Spare Operations 6-13
 - Testing All Spares 6-13
 - Blinking the Spare Drive Light 6-14
- Performing Disk Operations 6-15
 - Blinking the Drive Light 6-15
 - Downing the Drive 6-16
 - Pausing I/O to an Array Disk Drive 6-17

7 Scheduling and Monitoring Array Operations

- Setting Scheduling Options 7-1
- Viewing and Managing Scheduled Activities 7-3
- Monitoring Activities That Are Running 7-6

8 Setting Security Options

- Changing the Password 8-2
- Setting Password Time-out Options 8-3
- Controlling Guest Access 8-4

9 Managing Arrays and Spares

- Responding to a Critical Array 9-1
- Replacing a Spare 9-3
- Replacing an Active Array Member 9-4
- Responding to an Off-Line Array 9-5
 - Notes on Replacing Disk Drives 9-6
- Optimizing Array Performance 9-7
- Selecting a RAID Level for an Array 9-7

A Configuration Settings

- iomgr.ini A-2
- cioams.ini A-4
- Windows NT User Interface Variables A-6
- I/O Manager Settings A-7

B SAF-TE Enclosure Management

- Features of SAF-TE B-1
- Description of Events B-3

C Using the ArrayConfigSA Initial Boot Array Installation Utility

Creating an Array with ArrayConfigSA C-2

Making the Array Bootable C-5

Other ArrayConfigSA Options C-6

 Displaying Array Information C-6

 Deleting an Array C-6

 Initializing an Array C-7

 Creating and Deleting Spares C-9

 Adding a Disk to a Spare Pool C-9

 Deleting a Disk from a Spare Pool C-10

 Viewing Spare Pool Information C-10

 Adding a Dedicated Spare C-11

 Deleting a Dedicated Spare C-12

D SNMP/DMI Information

Index

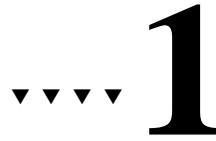

Getting Started

This document explains how to view SCSI devices and manage arrays with the Adaptec® CI/O™ Management Software. It includes instructions on using all the software features and also information on how to replace drives, reconstruct arrays, etc.

You install the Windows® client version of Adaptec CI/O Management Software on networked clients running under Windows® 95 or Windows NT™ 3.51 or 4.0. You may also install it directly onto servers running under Windows NT. Adaptec CI/O is used to monitor and manage server and array activities. CI/O gives you access to information on multiple servers to which the client is connected via the network and instant notification of storage-related problems.

This version of Adaptec CI/O Management Software (v3.3) supports the following Adaptec products:

- AIC-78xx devices (for example, the AHA-2940 host adapter) with the Adaptec 7800 Family Manager Set v2.10 or higher. Ultra2 SCSI host adapters require v3.00 or higher of the Family Manager Set (v3.01 or higher for Novell NetWare).
- ARO-1130SA, AAA-131SA, AAA-132SA, and AAA-133SA, with the Array1000SA Family Manager Set v. 3.3 or higher.
- These Adaptec bridge controllers: AEC-4312AS, AEC-4312AD, AEC-4412BS8, AEC-4412BD8, AEC-7312A, and AEC-7412B

In this document the Adaptec Array1000SA Family products and the Adaptec bridge controllers are sometimes referred to as “Adaptec RAID products” or “array controllers.”

Using the Adaptec CI/O Management Software

Here is some general information on using the Adaptec CI/O Management Software most effectively. Use the Table of Contents and the Index to find instructions for specific software commands.

- Use Adaptec CI/O Management Software to monitor the status of SCSI devices, arrays, and other devices on the server. This software allows you to receive status updates from multiple remote servers. You can simultaneously monitor servers running under different operating systems.
- Use Adaptec CI/O Management Software to set up regularly scheduled verification of fault-tolerant arrays and testing of spares. Respond immediately to arrays in *Critical* status, and replace failed spare disks promptly.
- Use Adaptec CI/O Management Software, running either on the server console or on a networked client, to add, delete, or reconfigure arrays after the server has already been in use. (You need special access rights to change the server configuration.)
- We recommend that you create a bootable array and boot the server from the array instead of from a stand-alone disk drive. You can create a bootable array with either Adaptec CI/O Management Software or the *ArrayConfigSA* program, which is described in Appendix C. (See the *Installation and Hardware Guide* for more information on configuring a bootable array.)
- Use the password feature of Adaptec CI/O Management Software to prevent unauthorized users from changing your array configuration.
- Be sure that arrays are adequately protected with spare pools (recommended) or dedicated spares. You can create and delete spares with any of the array management software programs.



Note: Your Adaptec product also includes the diskette-based *ArrayConfigSA* Initial Boot Array Installation Utility, which you can use to create arrays and spares. You can use *ArrayConfigSA* to create an initial bootable array for the server. See Appendix C, *Using the ArrayConfigSA Initial Boot Array Installation Utility*, for more information.

Conventions

This document uses the following typographic conventions:

bold

Used for key names (... press the **Enter** key ...) and for options you are told to select (... select **Configure SCSI Channels**...).

Helvetica

Used for screen messages (...**Save changes?**...) and for text that must be typed exactly as shown.

Helvetica Italics

Used for program and file names when referenced in the text (... these changes are made to the *config.sys* file...).



|

—

|

—

—

|

|

—

....2

Entering and Viewing Server Information

Adaptec CI/O Management Software allows you to view events taking place on multiple servers. In addition, you can view the configuration of SCSI devices, arrays, and other hardware on the server(s). This chapter explains how to view client and server information. Chapter 3 describes how to view SCSI adapters and devices. Chapter 4 explains how to view arrays, disks, and other SCSI devices attached to every controller within the server.



Entering and Viewing Server Information

Adding a New Server Address

You must enter information about each server you want to monitor with Adaptec CI/O Management Software. Once this information is recorded in a configuration file, Adaptec CI/O Management Software automatically finds the server(s) when restarting the application.

Adaptec CI/O Management Software User's Guide

Follow these steps to add a new server address to Adaptec CI/O Management Software:

- 1 Start the program by double-clicking the  icon in the Adaptec CI/O Management Software group.
- 2 Click the  button. The New Server dialog box appears, as shown in Figure 2-1.

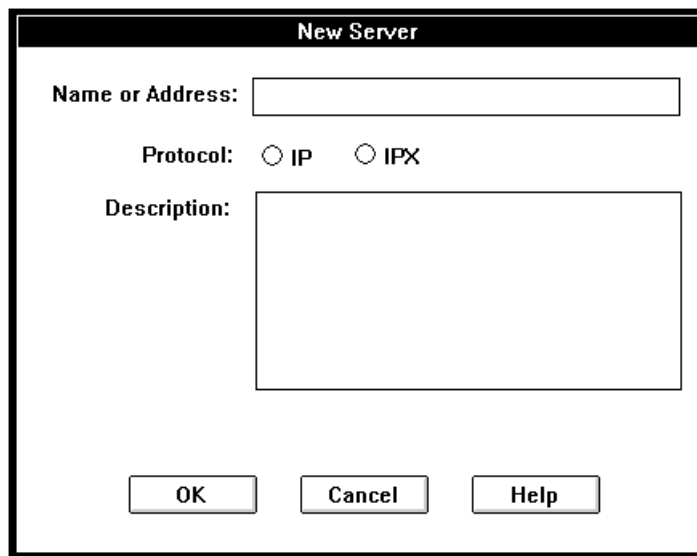

Figure 2-1. New Server Dialog Box

- 3 Select the **IP** or **IPX** radio button to indicate which kind of access is the default.
- 4 Enter the server's name or IP/IPX address, which can be up to 32 characters. This name will appear beneath the server icon in the Server View window.
 - Servers running under NetWare usually use IPX protocol. Select the **IPX** button and type the name of the server. To view the server name, open Windows File Manager, select **Connect Network Drive** from the Disk menu, and view the scrollable list of server names. If an error message appears when you click **OK** in the New Server dialog box, verify the

Entering and Viewing Server Information

server name and the use of IPX with the System Administrator.

If you need to enter an IPX address, the format is *xxxxxxxx.xx-xx-xx-xx-xx-xx*, where the first eight *x*'s are hex digits that define the network number, and the six pairs of hex digits are the host address or MAC address.

- Servers running under Windows NT usually use IP protocol. For Windows NT you can always enter the server address, if known. Otherwise, enter the server name. This could be something like *mainserver.unisystem.com* or *mainserver*. Be sure that the networked client is set up with either a host file or with the name of a domain resolver. Ask the System Administrator if you are not sure.

The format of a TCP/IP address is *nnn.nnn.nnn.nnn*, where each group of three decimal digits is a number between 0 and 255 (for example, 123.23.45.145).



Note: If you are only monitoring Windows NT servers, and you are *not* monitoring any NetWare servers, we recommend that you set the IPX= variable to 0 in the *cioams.ini* file. For more information, see the description of the IPX= variable under *cioams.ini* on page A-4. Appendix A also has information on other configuration options.

- 5 Enter a description of the server—for example, Application Server or Video Server. This description appears when you double-click the server icon in the Server View window.
- 6 Click **OK** to add the new server information. You will see one of the following error messages if the server name/address is not correct:
 - **RPC transport error.** This means that you entered a server address with correct IP or IPX syntax, but there is no server with this address. Check your typing for errors and try again.
 - **Transport not present.** This means that the selected protocol transport is not present.

- Duplicate server exists. This means that you entered a server name or address that has already been added for this networked client monitoring list.

Viewing and Editing Server Information

Follow these steps if you need to enter or change a server's network address information from the top menu bar of the CI/O Management Software main screen:

- 1 Click the  button on the toolbar. The Server View window appears. Each server is represented by an icon in the top part of the window. The appearance of the icon indicates the server status, as shown here:



Server is online and available.



Server is unavailable, perhaps due to a network failure. The Adaptec CI/O will automatically attempt to reattach to the server for a user-selectable time (default is 10 minutes). Double-click the server icon at any time to attempt a reattach.



Server has generated a critical event message.



Guest access to server is disabled. To access server information, double-click the icon and enter the server password when prompted.



Server has generated a warning event message, such as an array in Critical status.



Adaptec CI/O has lost communication with the server.

Entering and Viewing Server Information

- 2 Double-click a server icon in the Server View window. The Server Information dialog box appears, similar to Figure 2-2.

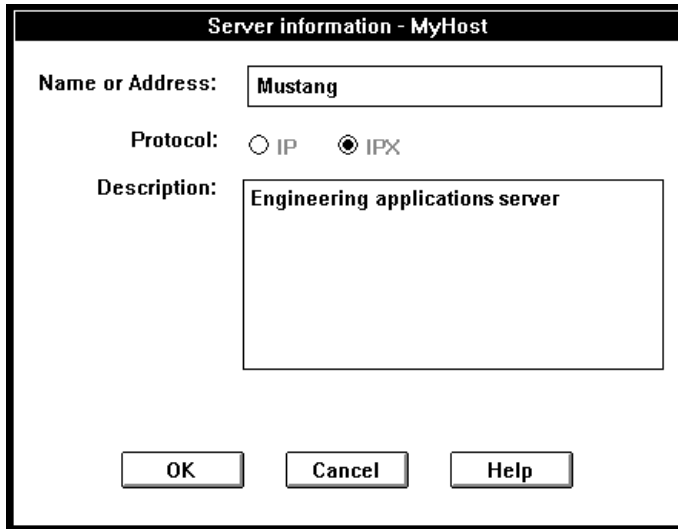



Figure 2-2. Server Information Dialog Box

- 3 View the server name, IP address, or IPX address.
- 4 View or edit the server description. The description is for your information only and appears only in this dialog box.
- 5 Click **OK** to exit the Server Information dialog box and to retrieve any updated server information.

Deleting a Server Address

When you delete a server address, the icon for the server no longer appears in the Server View window and you can no longer view information for that server or manage it with Adaptec CI/O Management Software.

Follow these steps to delete a server address:

- 1 Select **Server View** from the File menu.
- 2 Click the icon  of the server you want to delete.
- 3 Select **Server Delete** from the File menu. A prompt appears asking you to confirm the deletion of the currently selected server address.
- 4 Click **Delete** to delete the server address.



Note: If you attempt to delete a server address from a networked client while the server is off-line, the client will attempt to reconnect to the server. After this attempt fails, which may take a few seconds, the server address is deleted.

Viewing a List of Current Server Events

When you run Adaptec CI/O Management Software, you can use the Server View window to monitor events on all servers to which you are connected. Event notifications appear at the top of the list as they are received, starting from the time when you connect to the network. A color-coded circle at the beginning of each message gives you a quick indicator of its severity.

If you minimize Adaptec CI/O Management Software, the icon flashes whenever a new event notification is received.

Entering and Viewing Server Information

Follow these steps to view a list of current server events in the Server View window:

- 1 Select **Server View** from the File menu. The Server View window appears. The Global Current Event Log at the bottom of this window lists server events, as shown in Figure 2-3.

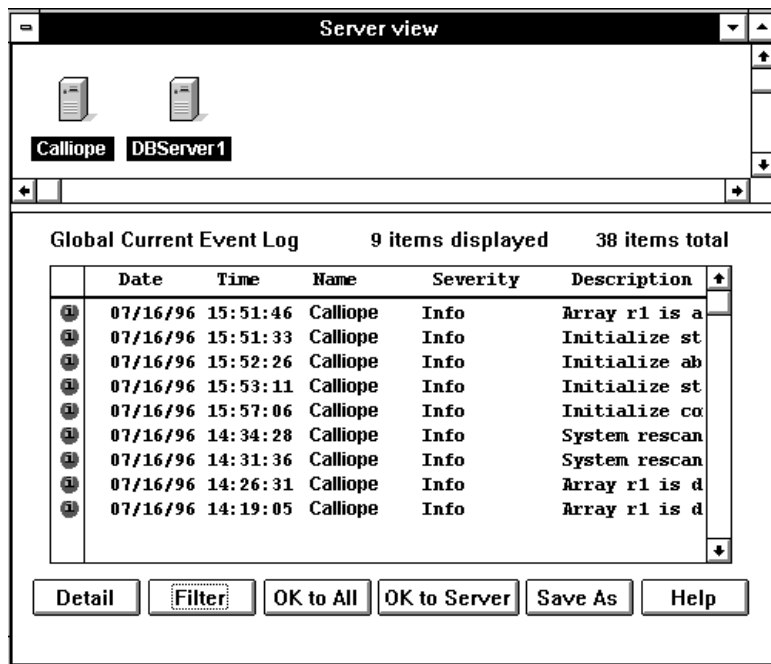

Figure 2-3. Listing of Server Events

- 2 View the event information for one or all servers. New entries appear on the list as the server events occur, and a date and time is listed for each event. See *Interpreting and Responding to Server Event Messages* on page 2-12 for more information on how to respond to these messages.



Note: The client sorts events from different servers in different time zones after adjusting the timestamp for each event to the client's local time. In other words, events are sorted correctly by absolute time of occurrence and are then displayed in the remote client's local time.

- 3 To view detailed information about an event, double-click the list entry. The Log Detail dialog box appears, as shown in Figure 2-4.

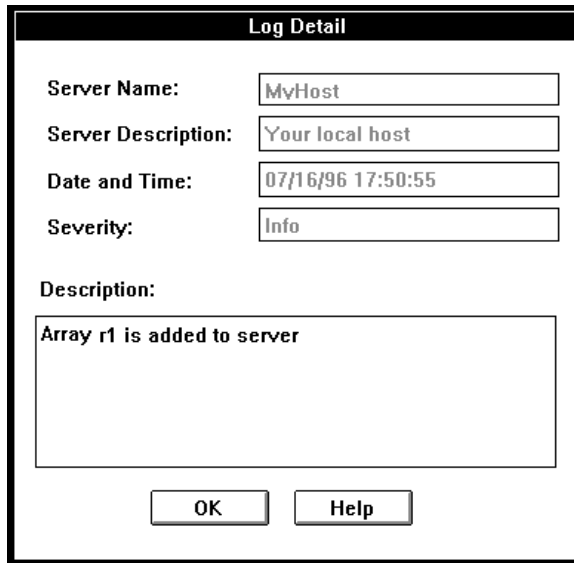

Figure 2-4. Log Detail Dialog Box

The information displayed in the Log Detail dialog box is similar to what appears in the one-line log entry, but the format is more readable.

- 4 Click **OK** when you are finished viewing the Log Detail dialog box. When you do this, you notify Adaptec CI/O Management Software that you have read the event notification.
 - To acknowledge all new event notifications *from all servers* without reading each individually, click **OK to All** at the bottom of the Server View window. This stops the Adaptec CI/O Management Software icon from flashing when the application is minimized.
 - To acknowledge all new event notifications *from the currently selected server* without reading each one individually, click **OK to Server** at the bottom of the Server View window.

Entering and Viewing Server Information

- 5 Click **Filter** in the Server View window to filter the events notifications in this window by severity. (See *Changing Filter Options* below.)
- 6 Click **Save As** to save the event list to a file.
- 7 Close the Server View window when you are finished viewing the server events or leave it open so you are aware of server events as they occur.

Changing Filter Options

You can control what kinds of event entries are listed in the Global Current Event Log (part of the Server View window) and the Historic Event Log window. You can set the Filter options globally, or you can customize them for individual windows. Follow these steps to change the filter settings globally:

- 1 Click the  button on the toolbar. The Preferences dialog box appears.
- 2 Click **Filter**. The Default Event Viewing Filter dialog box appears, as shown in Figure 2-5.

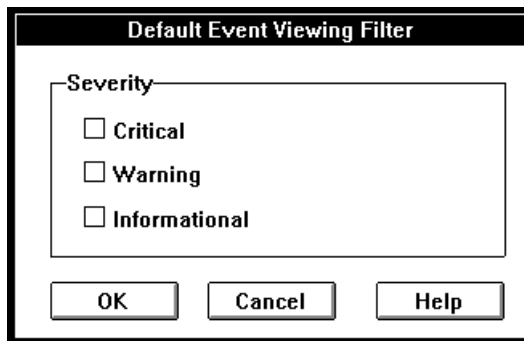

Figure 2-5. Default Event Viewing Filter

- 3 Select or deselect the **Critical**, **Warning**, or **Informational** entries to control which kinds of messages appear in the Global Current Event Log and the Historic Event Log. (We recommend that you select all the boxes.) If you choose not to display some kinds of messages, the *Items displayed* number above the log entries lists the number of messages that are

actually displayed. The *Items total* field always indicates the total number of messages of all types.

- 4 Click **OK** to record the Filter option changes.

To change the Filter options only for a specific window, open the Server View or Historic Event Log window and click **Filter**. Change the options as described above and click **OK**. The changed settings apply to this window only while it is open; the settings will return to the defaults if you close and re-open the window or if you restart Adaptec CI/O Management Software.

Choosing Notification Settings

The notification settings determine how you are notified of events that occur on servers to which Adaptec CI/O Management Software is connected. The text describing these events appears in the list of current server events and the Historic Event Log window.

Follow these steps to choose notification settings:

- 1 Click the  button on the toolbar. The Preferences dialog box appears.
- 2 Click **Notification**; the Event Notification Options dialog box appears, as shown in Figure 2-6.

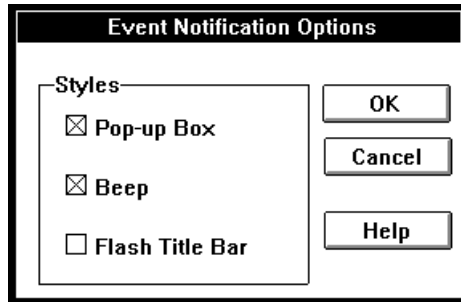

Figure 2-6. Event Notification Options Dialog Box

Entering and Viewing Server Information

- 3 Select **Pop-up Box**, **Beep**, and/or **Flash Title Bar** to control how you will be notified of events that occur on servers to which Adaptec CI/O Management Software is connected.



Note: Regardless of the options you choose, Adaptec CI/O Management Software will always notify you of Critical events with a pop-up message, a beep, and a flashing title bar.

- 4 Click **OK** to save these settings.

Viewing Historical Server Information

You can view a log of historical information for any single server to which Adaptec CI/O Management Software is connected. This information is retrieved from the server.

Follow these steps to view historical server information:



- 1 Click the  button on the toolbar. The Historic Event Log window for the currently selected server appears, as shown in Figure 2-7.

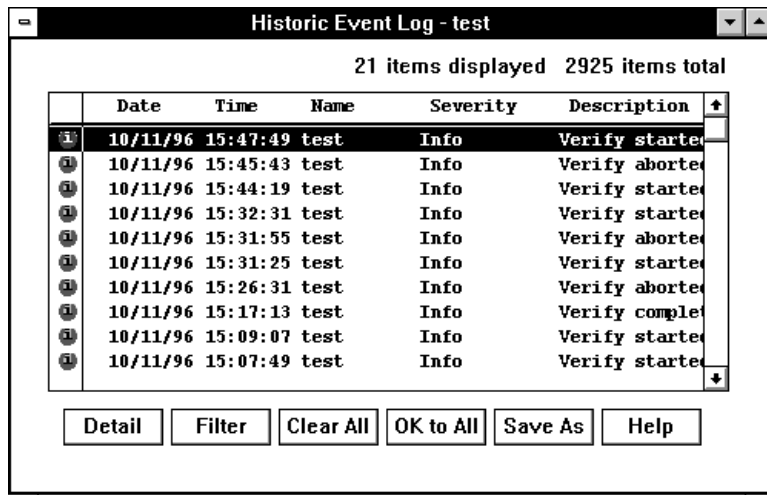

The screenshot shows a window titled "Historic Event Log - test". At the top, it says "21 items displayed 2925 items total". Below this is a table with columns for Date, Time, Name, Severity, and Description. The table contains 10 rows of data, all with a severity of "Info". The descriptions include "Verify started", "Verify aborted", and "Verify complete". At the bottom of the window, there is a toolbar with buttons for "Detail", "Filter", "Clear All", "OK to All", "Save As", and "Help".

	Date	Time	Name	Severity	Description
1	10/11/96	15:47:49	test	Info	Verify started
2	10/11/96	15:45:43	test	Info	Verify aborted
3	10/11/96	15:44:19	test	Info	Verify started
4	10/11/96	15:32:31	test	Info	Verify started
5	10/11/96	15:31:55	test	Info	Verify aborted
6	10/11/96	15:31:25	test	Info	Verify started
7	10/11/96	15:26:31	test	Info	Verify aborted
8	10/11/96	15:17:13	test	Info	Verify complete
9	10/11/96	15:09:07	test	Info	Verify started
10	10/11/96	15:07:49	test	Info	Verify started

Figure 2-7. Server Historic Event Log Window

- 2 View the historical information for the server. New entries are added to the top of the list as they occur. A color-coded circle at the beginning of each message indicates its severity. (See the next section, *Interpreting and Responding to Server Event Messages*, for more information.)
- 3 To view detailed information about an entry on the list, double-click the entry. The Log Detail dialog box appears, as shown in Figure 2-4 on page 2-8.
- 4 Click **OK** when you are finished viewing the Log Detail dialog box.
- 5 Click **Filter** to change the Message Filter options. Click **OK to All** to acknowledge all new event notifications without reading each one. (This stops the minimized Historic Event Log icon from flashing.) Click **Clear All** to delete all log entries. Click **Save As** to save the log to a file.





Note: When you open the Historic Event Log window, only the most recent log entries are initially displayed. If you scroll down beyond these entries, another group of entries are retrieved. This avoids the delay that might occur if an entire large log file were retrieved from the server at one time. To keep the Server Log file from getting too large, specify a maximum size for it in the initialization file. (See Appendix A, *Configuration Settings*.)

- 6 Close the window when you are finished viewing log entries, or minimize it as an icon on the screen.

Interpreting and Responding to Server Event Messages

There are three severity levels for server events:

-  **Critical** event messages (red) indicate an array or server problem that requires immediate action. An example is an array going off-line because two array members have failed. See *Responding to an Off-Line Array* on page 9-5 for more information.

-  **Warning** event messages (yellow) indicate an array or server problem that may require attention. An example is a paused channel or a fault-tolerant array with a failed disk. If no spare is available to replace the failed disk, take action immediately before another disk fails. See *Responding to a Critical Array* on page 9-1 for more information.
-  **Informational** event messages (green) contain information about a normal operation, such as creating a new array, adding a spare, or verifying an array.

Entering and Viewing Preference Information

You use the Preferences dialog box to enter or view information about how event notifications are received from servers and to enable and configure password protection for servers and networked clients.

Follow these steps to change or view preferences information:

- 1 Click the  button. The Preferences dialog box appears, as shown in Figure 2-8.

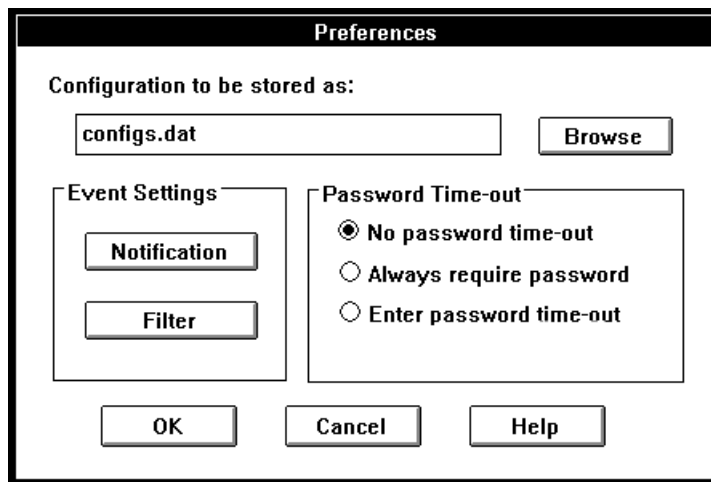

Figure 2-8. Preferences Dialog Box

- 2** You can enter a different name for the configuration file that is stored on the networked client. Click the **Browse** button if you want to store this file in a different directory on the client's hard drive.
- 3** Click **Notification** to change the way in which you are alerted of event notifications sent from servers. The Event Notifications Options dialog box appears, as shown in Figure 2-6 on page 2-10. Select one or more of the available options.
- 4** Click **Filter** to view the Log Filter dialog box. Select or deselect the check boxes, to filter the types of messages that appear in the window. We recommend that you select all the boxes so you are fully informed of server events.
- 5** Select a Password Time-out option to set the level of password protection for this workstation or server. See *Setting Password Time-out Options* on page 8-3 for more information.
- 6** Click **OK** to change the option information or to close the dialog box.

Editing the Permanent List

Each server maintains a *permanent list* and an *active list* of networked clients. Clients that communicate with the server are automatically added to the server's active list. Adding a client name to the permanent list allows that client to receive event notifications from the server even when it is not actively monitoring the server. (If a client is on the server's permanent list but not the active list, the server icon does not appear in the Server View window.) You can delete the client name if you no longer want to be notified of events on a particular server.

When you edit the permanent list, you are required to enter the server password.



Caution: We recommend that you do *not* use the Permanent Notification feature for normal communications between servers and networked clients. Servers can use the active list to rapidly communicate new events to networked clients.

Entering and Viewing Server Information

Follow these steps to add clients to or delete clients from the permanent list:

- 1 Open the Server View window and select the icon of the server whose permanent list you want to edit.
- 2 Select **Server Administration** from the View menu.
- 3 Select **Edit Permanent List**. Enter the server's password at the prompt. The Edit Permanent List dialog box appears, as shown in Figure 2-9.

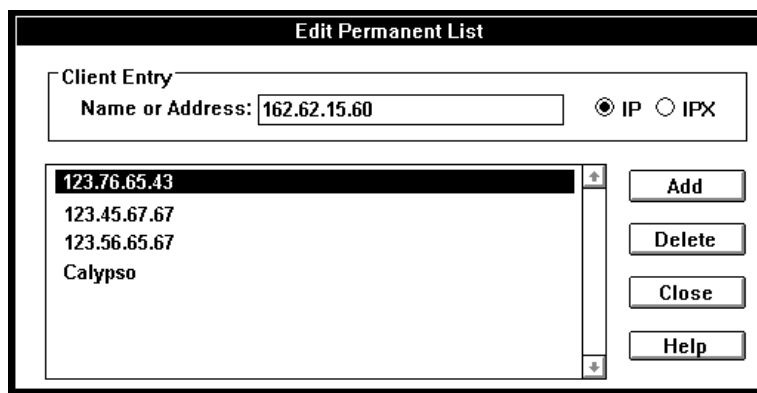

Figure 2-9. Edit Permanent List Dialog Box

The list box shows the entries that are currently in the selected server's permanent notification list.

- 4 To add a new networked client entry, type the IP or IPX address in the field at the top of the screen, select **IP** or **IPX**, and click **Add**.
- 5 To delete a networked client entry, highlight the entry in the list box and click **Delete**.
- 6 Click **Close** when you are finished. The changes are registered in the server's permanent list file.



|

—

|

—

—

|

|

—

... 3

Viewing SCSI Device Information

You can view the status of SCSI devices connected to one or more SCSI adapters from the Physical Resources window, as shown in Figure 3-1. Unlike SCSI devices and arrays associated with array controllers, these devices cannot be configured to create logical arrays from the graphical user interface. These devices are, however, checked and updated by a separate process that is specific to SCSI adapters. Refer to *Managing SCSI Adapters* on page 3-8.



Note: To view SCSI devices attached to AIC-78xx channels on Windows NT servers, Adaptec EZ-SCSI[®] software must be installed.

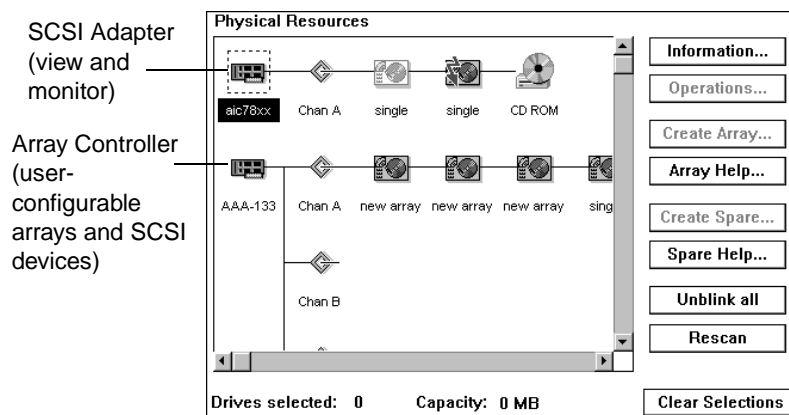

Figure 3-1. Physical Resources

Viewing Arrays from an External RAID Controller

A bridge controller connects Fibre Channel-to-SCSI or SCSI-to-SCSI external intelligent RAID array controllers to bridge the host I/O interface to multiple back-end device channels. Although these devices appear under a SCSI channel, they are capable of the same functionality as SCSI devices connected to array controllers. Figure 3-2 shows a bridge controller with a single "New Array" connected. For more information on how to view and configure arrays, refer to *Configuring Arrays and Spares* on page 4-1.

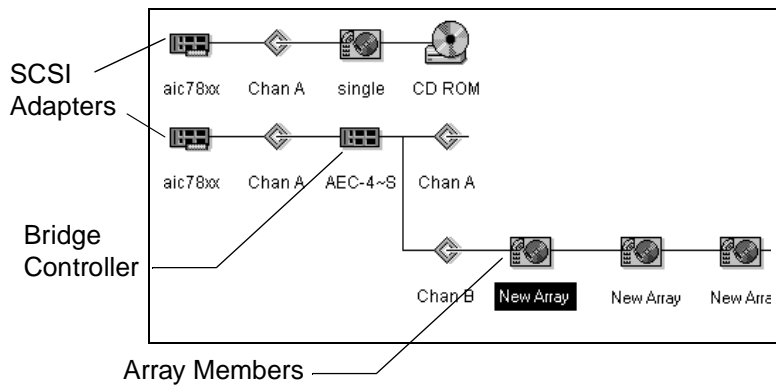



Figure 3-2. Detail of Bridge Controller and Arrays

Follow these steps to view configuration information for a device:









Note: The software scans the server every 3 minutes to detect status changes for any installed SCSI adapters and devices. No changes are detected until that scan has occurred. Changes to array controller status, in contrast, are detected immediately if I/O is present.

- 1 Select **Configuration** from the View menu, or click the  icon on the toolbar.

Viewing SCSI Device Information



- 2 When the Storage Configuration window appears, double-click the icon of the device for which you want information. The icons are as follows:

-  SCSI adapter, SCSI RAID card, or external RAID controller
-  Channel
-  Disk Device
-  CD-ROM Drive
-  Tape Drive
-  Scanner
-  Printer

The SCSI Device icons shown above represent physical devices that appear on the left side of the window. *Physical* means that the icons correspond to actual devices installed in the server, such as a SCSI drive or a CD-ROM drive.

The following sections explain the information that appears when you click an icon for a device.

Viewing the SCSI Information Dialog Box

When you double-click a SCSI Device icon, such as a disk  or a CD-ROM drive , the SCSI Information dialog box appears, as shown in Figure 3-3.

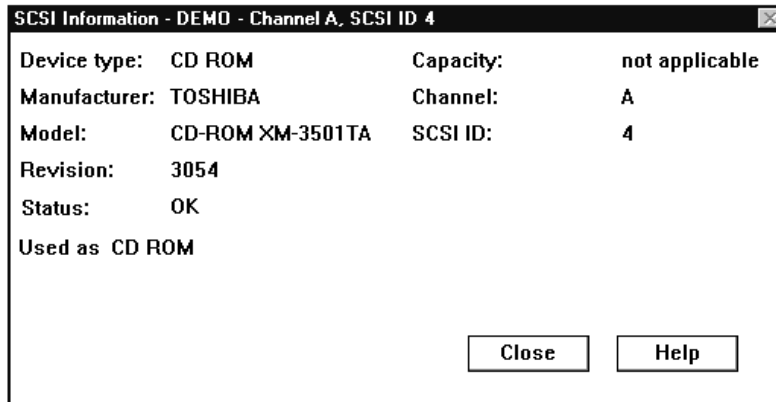

Figure 3-3. SCSI Information Dialog Box

The dialog box shows device type, manufacturer, model, channel, SCSI ID data, and other pertinent information for the specific device.



Note: Status field information is only provided for disk drives and CD-ROM drives.

Click **Close** to close the SCSI Information dialog box.

Viewing SCSI Adapter Information

When you double-click a SCSI Adapter icon , the Controller Information dialog box appears, as shown in Figure 3-4.

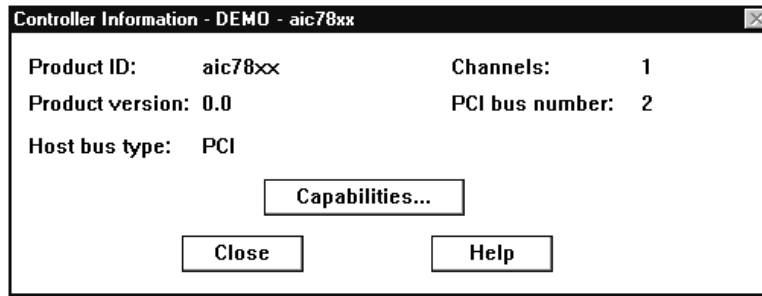



Figure 3-4. Controller Information Dialog Box

The *PCI bus number* field indicates which PCI slot the card is installed in.

Click **Capabilities** to view a list of the features supported by this device. You cannot enable or disable the capabilities on the list.

Click **Close** to close the Capabilities dialog box and the Controller Information dialog box.

Viewing SCSI Channel Information

When you double-click a Channel icon , the Channel Information dialog box appears, as shown in Figure 3-5.

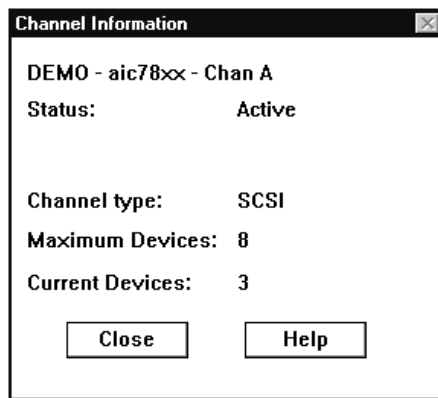

Figure 3-5. Channel Information Dialog Box

The following information appears in the Channel Information dialog box:

- **Status:** current operational status of the channel (for example, Active, Inactive).
- **Channel type:** type of this channel—for example, SCSI.
- **Maximum Devices:** maximum number of SCSI devices that the channel supports. The channel itself counts as 1 device so if this number is 16, for example, you can connect up to 15 devices.
- **Current Devices:** number of SCSI devices currently connected to the channel.

Click **Close** to close the Channel Information dialog box.

Rescan

After you have removed a device from the server, the user interface may continue to display it as disconnected in the Physical Resources dialog box. If this happens, you should select **Rescan**.

The Rescan function works differently for a SCSI adapter than it does for an Adaptec RAID product. A SCSI rescan deletes the database and then performs a discovery phase to find all devices connected to the server. An update is made to the user interface in the Physical Resources dialog box. Refer to *Managing SCSI Adapters* on page 3-8 for information on *discovery*.

With Adaptec RAID products, information is stored in reserved sectors. When you select Rescan, the program quickly updates the reserved sectors.

In contrast, information related to SCSI adapters is stored in the *iomaspi.dev* file. When the server boots up, it reads information from that file. When you select Rescan, the program deletes the file, rewrites it, and then updates the program.

Rescan Details

While adapters are being rescanned, the program displays indicators over each adapter icon to show that the rescan has not completed its discovery of all SCSI devices on that adapter.

If SCSI adapters and Adaptec RAID products are installed in the same server, the system will typically complete the rescan for the Adaptec RAID products, repaint the screen, then rescan the SCSI adapters. The repaint for SCSI adapters will not occur until the discovery of all adapters is complete.

Managing SCSI Adapters

SCSI devices that are attached to an Adaptec SCSI adapter are managed differently than those attached to an Adaptec RAID product. For each device attached to an Adaptec AHA[®]-2940 or AHA-1540, the Adaptec CI/O Management Software interrogates the system to detect possible device failures.

Adaptec CI/O Management Software performs three distinct tasks for SCSI adapters: Discovery, Poll, and Statistics. The time the software takes to detect system changes is directly affected by how the Discovery/Poll cycles respond. Devices that are new or recovered are detected at the next Discovery cycle; devices that have failed are detected at either the next Poll or Discovery cycle, whichever occurs first.

- **Discovery**—Analyzes the current configuration and compares it with the previous configuration. This phase requires that SCSI commands time out for every device that is not present. Therefore, the Discovery phase can be lengthy.

By default, the software runs the Discovery phase every 30 minutes. This can be modified in the *iomgr.ini* file on the server.

During the Discovery phase, the Adaptec CI/O Management Software performs the following steps:

- Determines the number of SCSI adapters installed
- Performs a host adapter inquiry on each installed SCSI adapter to determine its characteristics
- For each SCSI adapter, performs a SCSI inquiry command to every possible target device to determine the presence and characteristics of all devices

Adaptec CI/O Management Software records in an internal table all information discovered about SCSI adapters and devices. If an internal table already exists, discrepancies between the current system configuration and the internally recorded configuration are checked, tables are updated, and the display is updated.

- **Poll**—Validates Discovery information. Adaptec CI/O Management Software attempts to contact devices that are

Viewing SCSI Device Information

previously known to be present. By default, the software runs the Poll phase every 3 minutes, which can be modified in the *iomgr.ini* file on the server.

During this phase, the Adaptec CI/O Management Software performs the following steps:

- Verifies that the number of SCSI adapters is the same as in the Discovery phase
 - Performs an inquiry on each SCSI adapter that already appears in the internal tables to ensure that the adapter is still responding
 - Performs a device inquiry on each device in the internal tables to ensure that the device is still responding
 - Verifies that the information obtained from the device matches previous information
- **Statistics**—Collects I/O statistics. Adaptec CI/O Management Software collects read and write statistics from applicable devices. By default, the software runs the statistics phase every 10 seconds, which can be modified in the *iomgr.ini* file on the server.

During this phase, the following are performed:

- Iterates through all SCSI adapters and devices
- Gathers statistics for each SCSI adapter or device



|

—

|

—

—

|

|

—

4

Configuring Arrays and Spares

This chapter explains how to add and delete arrays and spares with the server console version or with the networked client version of the Adaptec CI/O Management Software. The menus and commands are the same for all supported versions of Windows.

You must know the Adaptec CI/O Management Software password to add and delete arrays and spares. See Chapter 8, *Setting Security Options*, for more information.

The following topics are explained in this chapter:

- *Creating an Array* on page 4-4
- *Making an Array the First Virtual Device* on page 4-10
- *Deleting an Array* on page 4-12
- *Initializing an Array* on page 4-13
- *Creating Dedicated Spares or a Spare Pool* on page 4-15
- *Deleting a Spare* on page 4-18
- *Managing Arrays on External RAID Controllers* on page 4-19



Note: These features are available for PCI array controllers and Bridge array controllers only. They are not available for SCSI adapters.

Starting the Program

Follow these steps to start the Adaptec CI/O Management Software and prepare to configure arrays and spares. This assumes that the software is already installed and that communications have been established between the server and the networked clients or other consoles:

- 1 Start Windows.

- 2 Double-click the  icon in the Adaptec CI/O Management Software group to start the program.



Note: If you are running Adaptec CI/O Management Software from a networked client and the message Guest Access Disabled appears at this point, the server to which you are trying to connect does not allow remote users to view its configuration information. See *Controlling Guest Access* on page 8-4 for more information.

- 3 Open the Server View window by clicking the  button on the toolbar.



Note: If no Server icons appear in the upper part of the window, enter information about the servers you want to monitor before you continue. See *Adding a New Server Address* on page 2-1 for more information.

Configuring Arrays and Spares

- Click the icon of the server whose arrays and spares you want to configure, as shown in Figure 4-1. You can identify the server by the name that appears beneath it.

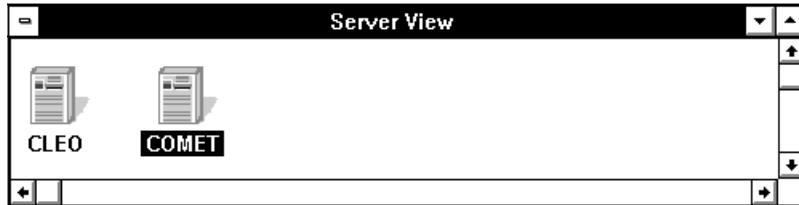

Figure 4-1. Server Icons

If the icon appears dimmed, the server is off-line or otherwise unavailable. (See *Entering and Viewing Server Information* on page 2-1 for more information about server icons.)

- Open the Storage Configuration window by clicking the



icon on the toolbar. All array and spare configuration tasks are done from within this window.



Note: Depending on your system configuration, the Storage Configuration window may open automatically when you start the Adaptec CI/O Management Software. See the *How-To Topics* section of the Adaptec CI/O Management Software online Help for more information about this window.

You can open other Storage Configuration windows for other servers to which you are connected. To do this, return to the Server



View window, select a different Server icon, and click the button again.

Creating an Array

Follow these steps to create arrays with Adaptec CI/O Management Software:

- 1 Start Adaptec CI/O Management Software and open the Storage Configuration window, as described in *Starting the Program* on page 4-2. This window looks similar to the one shown in Figure 4-2.

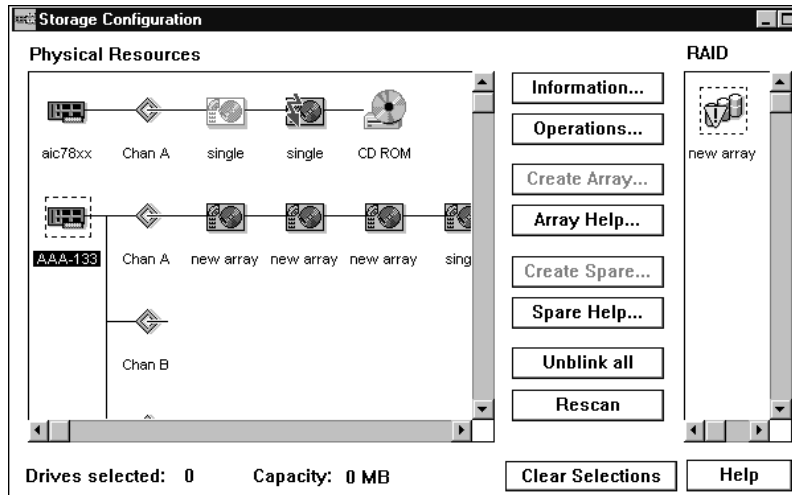

Figure 4-2. Storage Configuration Window

The icons on the left side of the Storage Configuration window represent the server's *physical resources*—the Adaptec RAID products, AIC-78xx products, channels, and SCSI devices installed in the server. The icons on the right side represent the server's *array resources*—the arrays and spares you define. You click the buttons in the middle of the window to perform operations on selected Device icons.

- 2 Before you start defining the new array, decide what RAID level you want to use, how many disks you want it to have, and whether you want to define dedicated spares (spares that can be used only by this array). The following table lists your Array options. See *Selecting a RAID Level for an Array* on page 9-7 for information on the advantages and disadvantages of each RAID level.

Configuring Arrays and Spares

RAID Level	Minimum Disks	Maximum Disks ¹	Dedicated Spares	Pool Spares ²
RAID 0 (Striped)	1 ³	16	None	None
RAID 1 (Mirrored)	2	2	1 or 2 ⁴	up to 8
RAID 0/1 (Mirrored & Striped) ⁵	4	16	1 or 2	up to 8
RAID 5 (Striped, with Distributed Parity)	3	16	1 or 2	up to 8

¹This is the maximum number of disks supported by the software driver. The maximum for your computer system may be less, depending on how many SCSI channels and devices you have.

²Pool spares are not supported on bridge controllers.

³The purpose of one-disk RAID 0 arrays is to give you more control over the virtual device order of disks controlled by the Adaptec RAID product. This is also useful for defining the system's boot device.

⁴Bridge controllers support up to 4 dedicated spares.

⁵RAID 0/1 arrays must have an even number of disks.

- 3 Select disks for the new array by clicking Disk icons  that have the word **Single** beneath them, as shown in Figure 4-3.

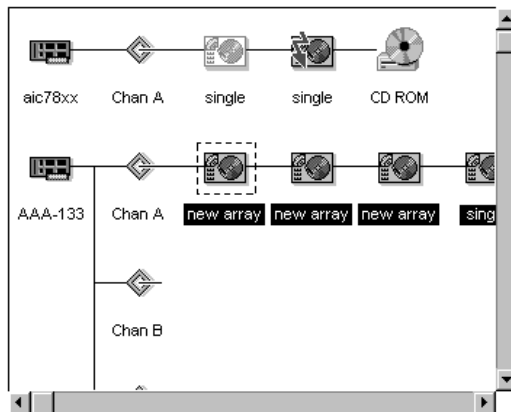

Figure 4-3. Selecting Array Members

Do not include disks that you want to use as dedicated spares. Click a second time on an icon to deselect it, or click the **Clear**

Selection button to deselect all disk icons. All array disks must be connected to the same Adaptec RAID product.



Note: Only devices attached to array adapters and external RAID controllers can be used for arrays and spares. Devices attached to SCSI adapters can only be viewed.

A warning appears if you select a disk that has a partition. If the operating system recognizes the partition, you *cannot* use the disk in the array. If the operating system does *not* recognize the partition (for example, if the disk was previously partitioned under another operating system), you *can* use the disk in the array.

You cannot use disks with recognized partitions for the array so you will not accidentally erase the server's boot disk. To

find out if a disk has a partition, double-click the  icon and click **Check Partitions** in the SCSI Information dialog box¹. A small popup box indicates whether the selected disk has a partition and whether the partition is visible to the operating system. To use a disk with a recognized partition in the array, exit from Adaptec CI/O Management Software, back up any data you want to keep, and delete the partition from the disk.



Caution: *All data on a disk is deleted when it becomes an array member! Back up any data you want to keep before selecting a disk as an array member.*

¹ The Check Partitions feature is not supported for arrays connected to bridge controllers.

- 4 Click **Create Array...** The Create Array dialog box appears, as shown in Figure 4-4.

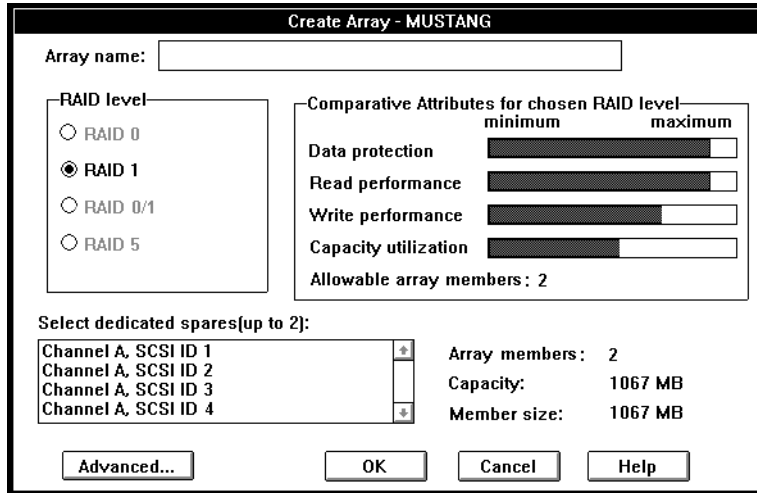

Figure 4-4. Create Array Dialog Box

The number of disks in the array and the array capacity are listed on the right of the dialog box.

- 5 Type a name for the new array. The name can be up to 15 characters, including spaces and any other printable characters.
- 6 Select a RAID level for the array by clicking one of the buttons on the left. The bar graphs on the right show the relative levels of data protection, read performance, write performance, and capacity utilization for each RAID level.

RAID levels appear dimmed if they are not consistent with the number of disks you have selected. (See the table on page 4-5.) For example, RAID 0/1 appears dimmed if you selected three disks, because a RAID 0/1 array must have at least four disks.

- 7 Select one or two disks from the list as dedicated spares¹. (Use **Ctrl-Click** to select multiple disks.) The disks on the list are the single disks you did not select as array members. The spare(s) you select should be at least as large as the smallest array

¹ Arrays connected to bridge controllers can have up to four dedicated spares each.

member. Otherwise the usable capacity of each array member will be reduced to the capacity of the spare.



Note: We recommend using a spare pool instead of dedicated spares¹. See *Creating Dedicated Spares or a Spare Pool* on page 4-15 for more information. Spares in a *spare pool* can be used by any array on the controller.

- 8 Click **Advanced...** to examine or change the Advanced Array options. The Advanced Array Options dialog box appears. See *Setting Advanced Array Options* on page 4-9 for more information.
- 9 Click **OK** and then click **Yes** to confirm that you want to create the array. If error messages appear, indicating that your array selections are inconsistent, change your selections and click **OK** again. A warning appears if you selected a dedicated spare that is smaller than the array members.

The array is initialized at this point, unless you deselected auto-initialize in Advanced Array options. (If you deselected auto-initialize, skip to 11.) To abort the initialization process (not recommended), open the Array Activity Monitor window,



select the icon for that array, and click **Abort**.

- 10 Wait until the new array is initialized. A popup box will appear to inform you that event notifications are waiting and can be viewed in the Server View window. Then an icon like



this icon for the new array appears in the right section of the Storage Configuration window. Another event notification is generated when the initialization process finishes.

¹ Bridge controllers do not support spare pools.



Note: Event notifications may appear as popups or as entries in the Server Historic Event Log and Event Log, depending on the Event Notification options you selected in the Client Settings dialog box.

- 11 Exit from Adaptec CI/O Management Software. Then reboot the server. (You cannot use the new array until you reboot.) You must partition the new array using the Windows NT Disk Administrator, just as you would partition a new stand-alone disk drive.

Setting Advanced Array Options

The Advanced Array Options dialog box is shown in Figure 4-5. *Do not* change these options from their default settings unless you have a specific reason to change them.

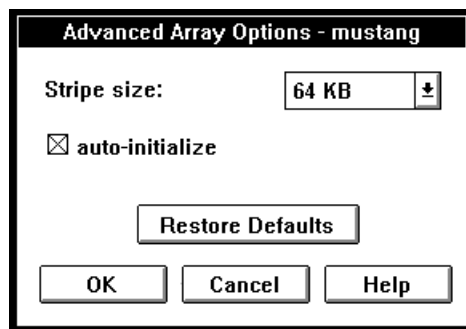

Figure 4-5. Advanced Array Options Dialog Box

Here is a brief description of the advanced options:

- **Stripe size** is the size that will be used to stripe data or parity information across the disks in the array. The optimal stripe size depends on factors such as the type of data being stored on the array and the server operating system. The default stripe size of 64 KBytes works best in most cases.
- Deselect **auto-initialize** to create the array now but initialize it at a later time. You can do this to define several arrays, then initialize them all at the same time.



Caution: All arrays except RAID 0 arrays *must* be initialized or low-level formatted before you can write data to them. We recommend that you zero-initialize RAID 0 arrays as well.

- Click **Restore Defaults** to restore the default Advanced Array Options settings.



Note: The *default settings* are the settings that existed when you opened the dialog box. If you change the settings and click **OK**, these become the new default settings for this array.

Making an Array the First Virtual Device

Use this command if you want the server to boot from an array instead of from a stand-alone disk.¹ (To use a stand-alone SCSI disk as your boot device, we recommend that you assign SCSI ID 0 to this device and that you connect it to Channel A of the Adaptec RAID product.)

You make an array bootable by assigning it virtual device order #0. The *virtual device order* is the sequence in which the server's operating system detects the arrays, single disks, and other devices connected to the Adaptec RAID product when the server boots. You may also need to move the Adaptec RAID product to a different PCI slot. See your Adaptec RAID product's *Installation and Hardware Guide* for more information.





Caution: When you make an array bootable, the drive letters assigned to other drives and arrays on the server may change, which can cause data access problems on your system.

¹ Bridge controllers do not support this feature.

Configuring Arrays and Spares

Follow these steps to create a bootable array:

- 1 Start Adaptec CI/O Management Software and open the Storage Configuration window, as described in *Starting the Program* on page 4-2
- 2 Click the icon  in the right part of the window for the array that you want to make bootable.
- 3 Click **Operations**.
- 4 Click  .
- 5 When the message appears, click **OK** to confirm that you want to make this array the boot device.
- 6 Exit from the Adaptec CI/O Management Software. If the selected array does not already have a bootable partition on it, reboot the server to a floppy disk.
- 7 Install the operating system on the array. See your Adaptec RAID product's *Installation and Hardware Guide* for more information.

The next time you boot the server, it will attempt to use this array as the boot device.

Deleting an Array



Caution: Back up the data on an array before you delete it. All data on the array disks is lost when you delete the array.

If you delete an array, all the disks that were part of the array become single, *stand-alone* disks. You can then use the disks as spares or as members of a new array.

Follow these steps to delete an array:

- 1 Start Adaptec CI/O Management Software and open the Storage Configuration window, as described in *Starting the Program* on page 4-2.

- 2 Click the icon  in the right area of the window for the array you want to delete.

- 3 Click **Operations**.

- 4 When the Array Operations dialog box appears, click



to delete the array.

A warning appears if the selected array has a partition. If the partition is recognized by the operating system, you *cannot* delete the array. If the partition is *not* recognized by the operating system, you *can* delete the array.

You are prevented from deleting an array with a recognized partition so you will not accidentally delete the server's boot array. To find out if an array has a partition, double-click the



icon and click **Check Partitions** in the Array Information dialog box.¹ A small popup box indicates whether the selected array has a partition and whether the partition is visible to the operating system. To delete an array with a

¹ The Check Partitions feature is not supported for arrays connected to bridge controllers.

recognized partition, exit from Adaptec CI/O Management Software, back up any data you want to keep, and delete the partition from the disk. Then start Adaptec CI/O Management Software again and delete the array.

- 5 When the confirmation message appears, click **OK** to confirm that you want to delete the array.



Note: After you delete an array you can immediately use the disks that formerly belonged to the array to create spares or a new array without rebooting the server. However, you must reboot the server before you can use the disks as single disks that are not members of an array. Deleting an array may change the boot order and the drive assignment.

Initializing an Array

When you create a new array it is initialized immediately by default unless you deselect the auto-initialize option, as described on page 4-9. If you deselect auto-initialize, you can initialize the array later by following the instructions in this section¹. You can also reinitialize an array that was previously zero-initialized or low-level formatted.



Caution: All arrays except RAID 0 arrays *must* be initialized or formatted before you can write data to them. We recommend that you zero-initialize RAID 0 arrays as well. All data on the disks is overwritten when you initialize an array.

Use the ArrayConfigSA™ program if you want to low-level format the array instead of initializing it with zeros². Low-level formatting checks the surface of the disks for defects. See Appendix C, *Using the ArrayConfigSA Initial Boot Array Installation Utility*.

¹ Arrays connected to external array controllers (bridge controllers) are automatically initialized when they are created. You cannot defer the initialization until a later time.

² ArrayConfigSA is not supported for arrays on bridge adapters. See the bridge adapter *Installation Guide* for more information.

Follow these steps to initialize an array to which data has previously been written or a new array that has been defined but not initialized:

- 1** Start Adaptec CI/O Management Software and open the Storage Configuration window, as described in *Starting the Program* on page 4-2.



- 2** Click the icon of the array you want to initialize. The Operations button becomes active.

- 3** Click **Operations**.

- 4** When the Array Operations window appears, click the



button.

A warning appears if the selected array has a partition. If the partition is recognized by the operating system, you *cannot* initialize the array. If the partition is *not* recognized by the operating system, you *can* initialize the array.

You are prevented from initializing an array with a recognized partition so you will not accidentally erase the server's boot array. To find out if an array has a partition, double-click the



icon, and click **Check Partitions** in the Array

Information dialog box.¹ A small popup box indicates whether the selected array has a partition and whether the partition is visible to the operating system. To initialize an array with a recognized partition, exit from Adaptec CI/O Management Software, back up any data you want to keep, and delete the partition from the disk. Then start Adaptec CI/O Management Software again and initialize the array.

- 5** When the confirmation message appears, click **Initialize** to confirm that you want to initialize the array.

¹The Check Partitions feature is not supported for arrays connected to bridge controllers.

To abort the initialization process (not recommended), open



the Array Activity Monitor window, select the icon, and click **Abort**.

It may take a long time to initialize an array. You can watch the progress of the initialization process in the Array Activity Monitor window.

Creating Dedicated Spares or a Spare Pool

Each RAID 1, 0/1, or 5 array can have one or two *dedicated spares*, which automatically replace failed disks *only* for that array¹. You can create dedicated spares when you create the array, or you can add them to the array at a later time. Each Adaptec RAID product can have a *spare pool* of multiple disks which automatically replace failed disks on *any* array on the Adaptec RAID product².

We recommend using a spare pool instead of dedicated spares if you have two or more arrays on an Adaptec RAID product. Spare pools give you more flexibility and provide good data protection with fewer disks than is required for dedicated spares.



Note: Adaptec CI/O Management Software is automatically configured to test all spares on the server once a day to assure they are always available to replace failed disks in arrays. We recommend that you not change this default setting.

Follow these steps to add a dedicated spare or a pool spare:

- 1 Start Adaptec CI/O Management Software and open the Storage Configuration window, as described in *Starting the Program* on page 4-2.
- 2 Select the disk you want to configure as a spare by clicking on its icon in the left part of the window. (Choose a disk that has the word **Single** beneath it.)

¹ Arrays connected to bridge controllers can have up to four dedicated spares each.

² Bridge controllers do not support spare pools.

- 3 Click **Create Spare...** The Create Spare dialog box appears, as shown in Figure 4-6. A list of already-defined spares appear on the right. Names of existing arrays appear on the left only if the disk you selected is large enough to protect that array as a spare.

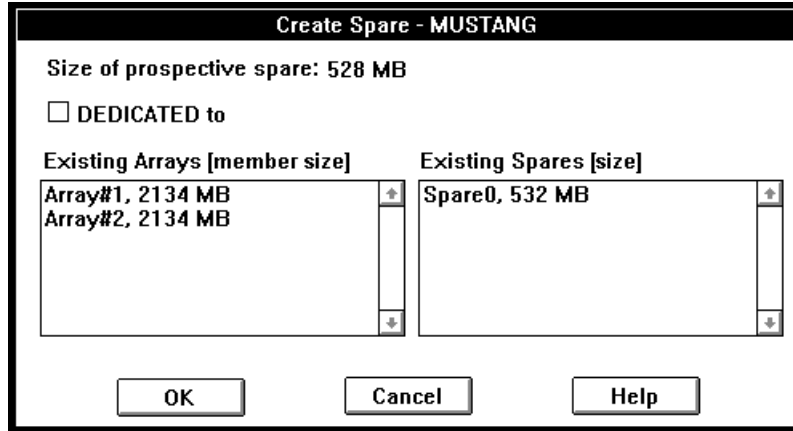

Figure 4-6. Create Spare Dialog Box



Note: In the Storage Configuration window, pool spares are labeled **p-spare** and dedicated spares are labeled **d-spare** in both the left and right parts of the window.

- 4 If you want to dedicate the spare to a specific array, select **Dedicated To** and click the array name in the scrollable list. If you want to add the spare to the pool of spares available to *all* arrays on the controller, *do not* select the **Dedicated To** box.
- 5 Click **OK** to create the spare. A warning message appears if you select a disk that has a partition. If the partition is recognized by the operating system, you *cannot* use the disk as a spare. If the partition is *not* recognized by the operating system (for example, if the disk was previously partitioned under another operating system), you *can* use the disk as a spare.

You are prevented from using disks with recognized partitions so you will not accidentally erase the server's boot disk. To

Configuring Arrays and Spares

find out if a disk has a partition, double-click the  icon and click **Check Partitions** in the SCSI Information dialog box¹. A small popup box indicates whether the selected disk has a partition and whether the partition is visible to the operating system. To use a disk with a recognized partition as a spare, exit from Adaptec CI/O Management Software, back up any data you want to keep, and delete the partition from the disk.

Newly-created spares are immediately available for use, without rebooting the server. If an array is in Critical status, it will be reconstructed as soon as you have created the spare (unless the spare is dedicated to another array).



Note: You can add a disk of any size to the spare pool, even if the disk is too small to protect the existing arrays. For example, if you have created two arrays with 1 GByte disks, you can add a 500-MByte disk to the spare pool, even though this disk is too small to replace any failed array member. This allows you to create a third array later with 500-MByte disks, for example.

To see which arrays are protected by an existing spare, select the spare in the Existing Spares list; the arrays protected by this spare are highlighted in the Existing Arrays list. You can double-click an array or a spare to view detailed information about it.

¹ The Check Partitions feature is not supported for arrays connected to bridge controllers.

Deleting a Spare

Follow these steps to delete a spare to use it as a stand-alone disk:

- 1** Start Adaptec CI/O Management Software and open the Storage Configuration window, as described in *Starting the Program* on page 4-2.
- 2** Click the icon in the Array part of the window for the spare you want to delete. The icons for dedicated spares are labeled "d-spare" and the icons for pool spares are labeled "p-spare."
- 3** Click **Operations**
- 4** When the Spare Operations dialog box appears, click the **Delete** button.
- 5** When the confirmation message appears, click **OK** to confirm that you want to delete the spare.

After you delete an existing spare, and before you reboot the server, you can use a former spare to create a new array or spare. However, this disk does not become visible to the server operating system as a single disk until after you reboot the server.

For information on replacing a spare disk, see *Replacing a Spare* on page 9-3.

Managing Arrays on External RAID Controllers

A bridge controller connects Fibre Channel-to-SCSI or SCSI-to-SCSI external intelligent RAID array controllers to bridge the host I/O interface to multiple back-end device channels. These devices appear under a SCSI channel, but are capable of the same functionality as SCSI devices connected to array controllers (see Figure 4-7 below). Refer to the sections on configuring and viewing arrays in this User's Guide for specific information on arrays.

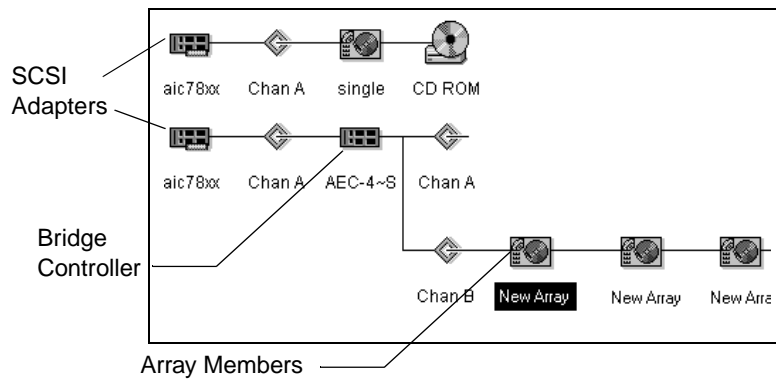

Figure 4-7. Arrays from External RAID Controller



|

—

|

—

—

|

|

—

5

Viewing Array and Device Information

The Adaptec CI/O Management Software allows you to view information about arrays, spares, and SCSI devices on any server to which you have access. You view this information in the Storage Configuration window. Follow these steps to open the Storage Configuration window:

- 1 Select **Configuration** from the View menu, or click the  icon on the toolbar.
- 2 When the Storage Configuration window appears, double-click the icon that represents the device for which you want to view information. Refer to Figure 5-1.

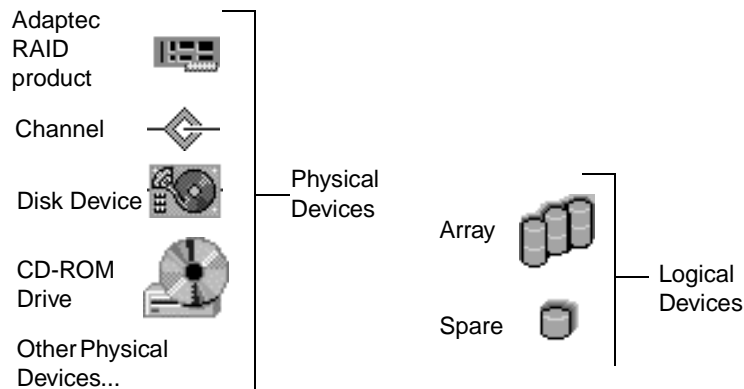

Figure 5-1. Storage Configuration Icons

The Array and Spare icons are “logical” devices that appear on the right side of the Storage Configuration window. *Logical* means that arrays and spares do not exist until you configure them on the server.

The Product, Channel, and SCSI device icons are physical devices that appear on the left side of the window. *Physical* means that the icons correspond to actual devices installed in the server, such as a SCSI drive or a CD-ROM drive.

The following sections explain the information that appears when you click an icon for a logical or physical device.

Viewing Array Information



When you double-click an Array icon in the Storage Configuration window, the Array Information dialog box appears, as shown in Figure 5-2.

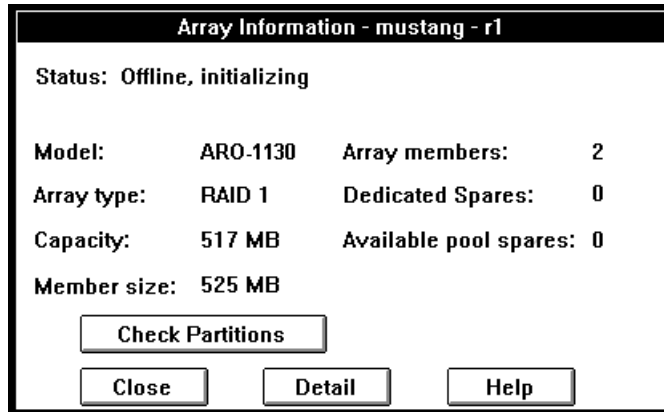

Figure 5-2. Array Information Dialog Box

The following information appears in the Array Information dialog box:

- **Status:** current status of the array, such as OK, Off-line, Fault-tolerant, Critical, etc.

Viewing Array and Device Information

- **Model:** model name of the Adaptec product to which the array disks are connected.
- **Array type:** RAID level of the array. The supported levels are RAID 0, RAID 1, RAID 0/1, and RAID 5.
- **Capacity:** total usable disk space available in the array, in MBytes.
- **Member size:** size of the array members.
- **Array members:** number of disks in the array.
- **Dedicated spares:** number of spare disks dedicated to this array.
- **Available pool spares:** number of pool spares available to protect this array.

Click **Check Partitions**. A small dialog box indicates whether the selected array has a partition and whether the partition is visible to the operating system.

When you click **Detail**, you can view the following additional information about the array:

- **Stripe size:** data and parity striping size used on this array.
- **Virtual device order:** the sequence in which the server's operating system detects this array when it boots. If the array's virtual device order is 0, then this array is the first device the operating system detects at boot time.
- **Creation date:** date on which the array was created.
- **Date of last verify:** date on which the array was last verified. See *Verifying Array Integrity* on page 6-7 for information on how to verify an array.
- **Date of last reconstruct:** date on which the array was last reconstructed. See *Reconstructing an Array* on page 6-2 for information on how to reconstruct an array.

Click **Close** to close the Array Detail and Array Information dialog boxes.

Viewing Spare Information

When you double-click a Spare icon  in the *right* side of the Storage Configuration window the Spare Information dialog box appears, as shown in Figure 5-3.

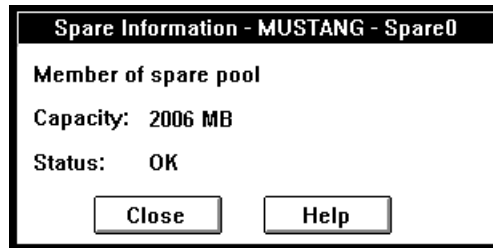

Figure 5-3. Spare Information Dialog Box

When you double-click a Spare icon in the *left* side of the window, the SCSI Information dialog box appears, as it does for a single SCSI disk.

The Spare Information dialog box shows which array the spare is dedicated to, whether it is a member of a spare pool, its capacity, and its current status. An *Available* status means the spare is fully functional and is available to replace a failed array disk.



Note: The Spare icons in the Storage Configuration window are labeled p-spare for pool spares and d-spare for dedicated spares.

Click **Close** to close the Spare Information dialog box or SCSI Information dialog box.

Viewing SCSI Device Information from an Array Controller

SCSI devices can be connected to array controllers as well as to SCSI adapters. The same SCSI device information is provided in both cases. See *Viewing the SCSI Information Dialog Box* on page 3-4 for a description of the SCSI Information Dialog Box.



Note: You cannot use a disk in an array if it has a partition that is visible to the operating system. (This prevents you from accidentally deleting data or erasing your boot disk.) To use a disk with a recognized partition in the array, exit from the Adaptec CI/O Management Software program, back up any data you want to keep, delete the partition, and then run the program again.

Rescanning the Server

Whenever you boot the server, the operating system software scans the server for installed devices such as arrays and SCSI devices. Adaptec CI/O Management Software displays icons for these devices in the Storage Configuration window.

You may need to issue a Rescan command while Adaptec CI/O Management Software is running so it can “see” the new hardware configuration. You need to do a rescan if

- You connect a new SCSI device to the Adaptec RAID product without using the Pause I/O command
- You disconnect a SCSI device from the Adaptec RAID product without using the Pause I/O command

A rescan is done automatically whenever you pause I/O and resume I/O to an array or a device. You do not need to issue a Rescan command to detect a failed array member. Adaptec CI/O Management Software will detect the failed member automatically if I/O is occurring on the array.

Follow these steps to rescan the server:



- 1** Click the  button on the toolbar. The Storage Configuration window appears.
- 2** Click **Rescan** in the area between the Physical Resources and Array areas of the window.
- 3** When the message appears, click **Yes** to confirm that you want to rescan the server. When the rescan is complete, any hardware changes are reflected in the icons in the Storage Configuration window.
- 4** Click **OK** when the message appears indicating that the rescan was completed successfully.



Note: You cannot use the Rescan command to recognize an entire array that was transferred from another server. You must reboot the server before it recognizes the transferred array. However, if you remove a disk that is an array member, replace it with another disk, and issue a Rescan command, Adaptec CI/O Management Software will detect that the new disk is no longer an array member.

Viewing Array Controller Information

When you double-click an icon for an Adaptec RAID product

 , the Controller Information dialog box appears, as shown in Figure 5-4.

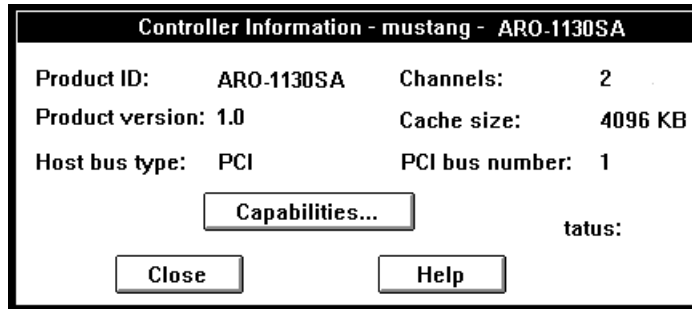

Figure 5-4. Controller Information Dialog Box

The information in the Controller Information dialog box is self-explanatory. The *PCI bus number* field indicates which PCI slot the Adaptec RAID product is installed in. You may need this information to configure the server to boot from an array. For more information, read the server documentation.

Click **Capabilities** to view a list of the features supported by this Adaptec RAID product. The list is informational only; you cannot enable or disable the capabilities on the list. These are controller capabilities that may appear on the list (not all features appear for every product):

- **Auto Verify:** indicates that the Adaptec RAID product automatically verifies SCSI parity.
- **Auto Fix:** indicates that the Adaptec RAID product automatically corrects data and parity mismatches.
- **Supported RAID Levels:** lists the RAID levels the Adaptec RAID product supports.
- **Maximum Number of Spares:** lists the maximum number of dedicated spares per array that the Adaptec RAID product supports.

Adaptec C/I/O Management Software User's Guide

- **Maximum Number of Physical Arrays:** lists the maximum number of arrays the Adaptec RAID product supports.
- **Maximum Number of Drives for a Single Array:** lists the maximum number of disks the Adaptec RAID product supports for a single array.
- **Maximum/Minimum Stripe Size:** lists the range of data and parity stripe sizes that the Adaptec RAID product supports.
- **Spare Pool:** indicates that the Adaptec RAID product supports using spares from a spare pool.

Click **Close** to close the Capabilities dialog box and the Controller Information dialog box.

Viewing Channel Information

When you double-click a Channel icon , the Channel Information dialog box appears, as shown in Figure 5-5.

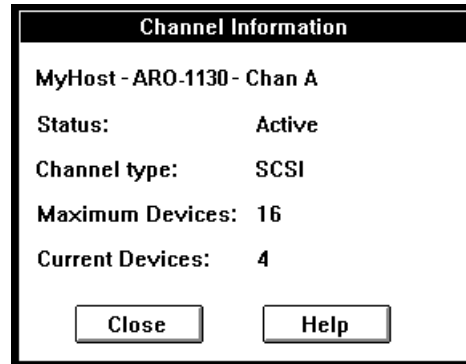

Figure 5-5. Channel Information Dialog Box

The following information appears in the Channel Information dialog box:

- **Status:** current operational status of the channel (for example, Active, Inactive).
- **Channel Type:** type of this channel—for example, *SCSI*.
- **Maximum Devices:** maximum number of SCSI devices that the channel supports. For example, if this number is 16, you can connect up to 15 devices, since the channel itself counts as one device.
- **Current Devices:** number of SCSI devices currently connected to the channel.

Click **Close** to close the Channel Information dialog box.



|

—

|

—

—

|

|

—

...6

Performing Array, Spare, and Disk Operations

In Adaptec CI/O Management Software you can perform a number of operations on arrays, spares, and stand-alone disks. These operations include verifying the parity of arrays, reconstructing an array, testing spares, and blinking the lights on one or more disks. Some of the operations are performed immediately; others can be scheduled for a later time, or scheduled to occur periodically at stated intervals.



To perform array, spare, and disk operations:

- 1 Select **Configuration** from the View menu, or click the



icon on the toolbar.

- 2 When the Storage Configuration window appears, *single-click*

the icon that represents the array  , spare  , or SCSI

disk  you want to work on.

When you do this, the Operations button becomes active.

- 3 Click **Operations**. The Array Operations, Spare Operations, or Disk Operations dialog box appears.

- 4 Click the button for the operation you want to perform. See the appropriate section of this chapter for a description of these operations.

Performing Array Operations

A list of the array operations follows. Note that some of these operations are described in Chapter 4, *Configuring Arrays and Spares*.

- *Reconstructing an Array* on page 6-2
- *Pausing I/O on an Array* on page 6-5
- *Verifying Array Integrity* on page 6-7
- *Blinking Array Drive Lights* on page 6-9
- *Reactivating an Off-line Array* on page 6-10
- *Changing an Array Name* on page 6-11
- *Forcing a Spare* on page 6-11
- *Making an Array the First Virtual Device* on page 4-10
- *Creating an Array* on page 4-4
- *Initializing an Array* on page 4-13

Reconstructing an Array

If a spare disk is available when an array disk fails, the array is automatically reconstructed, and you do not need to use the Reconstruct operation. However, if a disk in an array fails and no spare is available to replace it, you receive an event notification that the array is Critical. You may need to reconstruct the array with this command after the drive is replaced. In either case, data on the array is not lost.

You can reconstruct an array immediately after you replace the failed disk, or you can schedule the reconstruct to occur at a later time. Since the reconstruction process may take a long time, you may want to schedule it for a time when there is less activity on the server.



Note: The Verify operation can take up to several hours for a large array.

Follow these steps to reconstruct an array when a disk fails:

- 1 Determine which array is in Critical status and which disk in the array has failed.

It is possible that a RAID 0/1 array in Critical status may have more than one failed disk. The array can still be reconstructed without data loss as long as at least one disk of each mirrored pair is still good.
- 2 If the array enclosure does not support hot swapping¹, pause I/O to the array. (See *Pausing I/O on an Array* on page 6-5.) This is not necessary if the array enclosure does support hot swapping.
- 3 Replace the failed disk (or disks) with a good disk of at least the same storage capacity. Be sure that the SCSI ID of the new disk is different from the SCSI ID of other installed devices. Or, if an array disk was accidentally disconnected, reconnect it.
- 4 If you paused I/O in Step 2, wait until it automatically resumes after the pause period. If you did not pause I/O, issue a Rescan command to detect the new disk.
- 5 If you installed a new disk (or disks), make the disk into a spare by following the directions in *Creating Dedicated Spares or a Spare Pool* on page 4-15. Be sure the new spare disk is at least as large as the smallest array member.



Note: When the spare is created, Adaptec CI/O Management Software should automatically start a Reconstruct operation on the array. If for some reason the reconstruct does *not* begin automatically, follow the remaining steps to perform it manually.

¹ *Hot swapping* support means that the array enclosure electrically isolates the bad disk's SCSI connector from the SCSI bus while the disk is being swapped to prevent data corruption. Data can still be transferred to and from the remaining good disks while the bad drive is replaced.

- 6 Select **Configuration** from the View menu. The Storage Configuration window appears.

- 7 Click on the Array icon that looks like this . The Operations button becomes active.

- 8 Click **Operations**. The Array Operations dialog box appears, as shown in Figure 6-1.

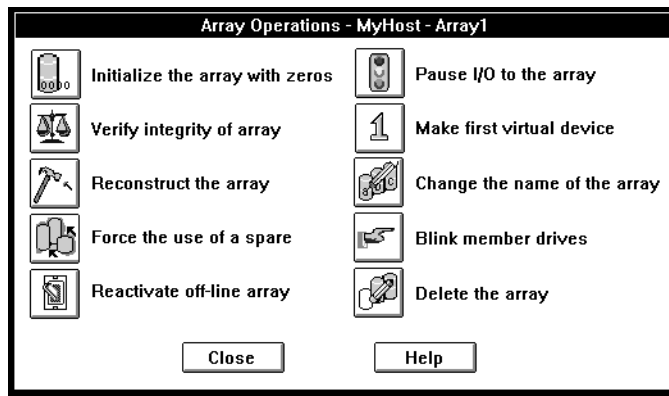



Figure 6-1. Array Operations Dialog Box

- 9 Click the  button. If the array has one failed drive the Scheduler dialog box appears.

If you have a RAID 0/1 array with two or more failed disks, and at least one disk of each mirrored pair is still good, a dialog box appears with a list of the failed drives. You must reconstruct the disks one-at-a-time, starting over each time at the beginning of these steps. Select one of the drives on the list and click **OK**; the Scheduler dialog box appears. (This assumes that you have already physically replaced all of the failed drives with good drives.)

- 10 Enter the required information for the Reconstruct operation in the Scheduler dialog box. You can select **Immediate** to reconstruct the drive immediately or select **Once** to schedule the operation for a later time. (See *Setting Scheduling Options* on page 7-1 for more information.)

- 11 Select an Execution priority - **high**, **medium**, or **low**.
- 12 Click **OK**.
- 13 When the message appears, confirm that you want to reconstruct the array member.
- 14 Read the event notifications that appear in the Server View window (they may also appear as popups on the screen) to determine when the reconstruct is complete.

Open a Watch box if you want to monitor the progress of the array reconstruction. (See *Monitoring Activities That Are Running* on page 7-6.)

Pausing I/O on an Array

Use this option to temporarily stop I/O transactions on the SCSI bus while you replace a disk or reconnect a loose connection in an array enclosure that does not support hot swapping¹. If your array enclosure supports hot swapping, you probably do not need to pause I/O to replace a disk. See the array enclosure documentation for more information.

When you pause an array, all other devices on all channels on the Adaptec RAID product are also paused. I/O is automatically resumed after a specified pause interval.



Caution: Pause I/O cannot assure the same level of protection from electrical noise that you have when you replace a disk in an enclosure that supports hot swapping. Every time you use this feature, you should only perform one action—either disconnecting a drive or inserting a drive, but not both. *Do not* replace a non-downed drive in a paused array, as this may cause data to be corrupted. Instead, down the drive first and then replace it.

¹ *Hot swapping* support means that the array enclosure electrically isolates the bad disk's SCSI connector from the SCSI bus while the disk is being swapped to prevent data corruption. Data can still be transferred to and from the remaining good disks while the bad disk is replaced.

Follow these steps to pause and resume I/O on an array:

- 1 Open the Storage Configuration window and select the icon of

the array  you want to pause.

- 2 When the Array Operations dialog box appears, click the



- 3 When the Pause I/O dialog box appears, enter a pause interval that does not exceed the maximum allowable pause period, and click **OK** to pause the array.



Note: The Minimum pause period is 5 seconds; the maximum pause period is 120 seconds. The Pause I/O command is disabled if a Verify, Reconstruct, or Initialize operation is running.

- 4 Remove or replace the disk drive, as required. Data I/O resumes automatically at the end of the pause period.



Caution: You must replace the device with the same kind of SCSI device. You should *not*, for example, replace a disk drive with a CD-ROM drive while I/O is paused.

Verifying Array Integrity

Use this option to verify the integrity of redundant data stored on fault-tolerant (RAID 0/1, RAID 1, RAID 5) arrays. When you run this operation, Adaptec CI/O Management Software checks the array for mismatches and corrects parity errors automatically. A *miscompare* occurs when the parity information on a RAID 5 array does not match the user data or when some part of the data on a mirrored disk pair in a RAID 0/1 or RAID 1 array does not match.

In Adaptec CI/O Management Software you can schedule the Verify operation to run later or schedule it to run at a regularly occurring interval. We recommend that you schedule a verification of all arrays at least once a week. See *Setting Scheduling Options* on page 7-1 for more information.



Caution: You should run the Verify operation immediately on all fault-tolerant arrays after any kind of system failure, including a disorderly system shutdown. A failed drive in an array cannot be reconstructed if the data is inconsistent.

Follow these steps to verify the integrity of redundant array data:

- 1 Select **Configuration** from the View menu. The Storage Configuration window appears.
- 2 Click on the Array icon . The Operations button becomes active.
- 3 Click the **Operations** button.

- 4 When the Array Operations dialog box appears, click the



button to verify the data on the array. The Scheduler dialog box appears, as shown in Figure 6-2.

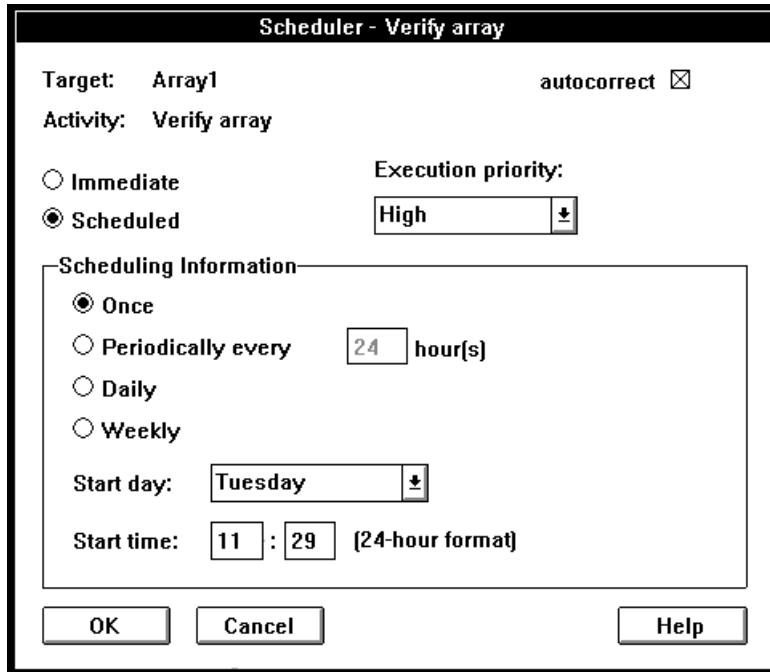

Figure 6-2. Scheduler Dialog Box

- 5 Leave the **autocorrect** box checked so that any data parity or mirroring mismatches will be corrected automatically.
- 6 Select **Immediate** if you want to verify parity immediately, or select **Scheduled** if you want to schedule the operation for a future time.

Performing Array, Spare, and Disk Operations

- 7 If you select **Scheduled**, enter a start time, start day of the week, and other information. (See *Setting Scheduling Options* on page 7-1 for more information.)
- 8 Select an Execution Priority - **high**, **medium**, or **low**. This sets the system resources devoted to the operation. A high priority for the Verify operation requires a lot of system resources, which may slow down other system activity.
- 9 Click **OK** to start the operation (if you selected **Immediate**) or to enter it on the list of scheduled activities.
- 10 When the message appears, confirm that you want to verify parity information.



Note: The Verify operation can take up to several hours for a large array.

You can open a Watch window to monitor the progress of the operation as it is running. See *Monitoring Activities That Are Running* on page 7-6 for more information.

Blinking Array Drive Lights

You can issue a command to blink the drive lights of all the disks in a selected array. This allows you to see which physical drives actually form the array.



Note: Adaptec CI/O Management Software does not support blinking the drive lights on CD-ROM drives.

Follow these steps to blink the drive lights of the disks in an array:

- 1 Select **Configuration** from the View menu. The Storage Configuration window appears.
- 2 Click on an Array icon in the right side of the dialog box. The Operations button becomes active.
- 3 Click the **Operations** button.

- 4 When the Array Operations dialog box appears, click the



button.

- 5 Look at the array enclosure to see which disks are members of the array.
- 6 Click the **Unblink all** button in the Storage Configuration dialog box to stop the drive lights from blinking.

Reactivating an Off-line Array

An array may go off-line because a cable is disconnected or because you mistakenly remove the wrong disk while trying to replace a failed disk. In these situations, the array shuts down temporarily. Depending on the reason that the array went off-line, it is possible to reactivate it and resume I/O without data loss. See *Responding to an Off-Line Array* on page 9-5 for more information.

After you correct any hardware problems, follow these steps to reactivate an off-line array:

- 1 Select **Configuration** from the View menu. The Storage Configuration window appears.
 - 2 Click on the dimmed icon of the off-line array. The Operations button becomes active.
 - 3 Click **Operations**.
 - 4 When the Array Operations dialog box appears, click the
- 
- button.
- 5 When the message appears, confirm that you want to reactivate the array. Be sure that any hardware problems are corrected before you do this.

Changing an Array Name

When you create an array, you assign it a name. This name appears beneath the Array icon and in many of the windows and dialog boxes. It is also used to identify the source of event notifications. You can change this name at a later time.

Follow these steps to change the name of an existing array:

- 1 Select **Configuration** from the View menu. The Storage Configuration window appears.

- 2 Click the icon  of the array whose name you want to change. The Operations button becomes active.

- 3 Click **Operations**.

- 4 When the Array Operations dialog box appears, click the



button. The Change Name dialog box appears.

- 5 Type the new array name and click **OK**.
- 6 When the confirmation message appears, confirm that you want to change the array name. This change appears immediately in the Storage Configuration window.

Forcing a Spare

Forcing a spare means issuing a command for a spare disk to replace a specific disk in an array. You can do this if the array disk is not performing well and has generated a S.M.A.R.T. predictive failure event notification¹. (If an array member actually does fail, a spare replaces it automatically without requiring you to force a spare.)

¹S.M.A.R.T. stands for Self-Monitoring Analysis and Reporting Technology. Hard drives that support this technology continually analyze their performance and generate an alert if they determine that the disk is likely to fail in the next few hours. Adaptec CI/O Management Software generates an event notification if it receives this alert, allowing you to replace the disk before it actually fails.

Follow these steps to force a spare:

- 1** Be sure that one or more spares are available for the array. These can either be dedicated spares for the array or spares from a spare pool. See *Creating Dedicated Spares or a Spare Pool* on page 4-15 for more information on configuring spares.
- 2** Select **Configuration** from the View menu. The Storage Configuration window appears.
- 3** Click on the icon of the array with the suspect disk. The Operations button becomes active.
- 4** Click **Operations**.
- 5** When the Array Operations dialog box appears, click the  button. This button appears dimmed if no spares are available.
- 6** Select the disk that you want to replace.
- 7** Click **OK** to replace this disk with a spare.
- 8** When the confirmation message appears, confirm that you want to replace the disk with the spare.

At this point data I/O is paused to the disk, and the spare is automatically activated to replace it.

If there is a pool of available spares, you cannot control which disk from the pool is activated when you force a spare. You can control this if there is only *one* dedicated spare or *one* pool spare. If both dedicated spares and pool spares are available, the dedicated spares are used first. If an error message indicates that the pool spare is not at least as large as the smallest disk in the array, add a larger spare.

Performing Spare Operations

The following are spare operations available in Adaptec CI/O Management Software.

- *Testing All Spares* on page 6-13
- *Blinking the Spare Drive Light* on page 6-14
- *Deleting a Spare* on page 4-18



Note: All spare operations apply only to the *spares on the currently selected server*.

Testing All Spares

Reliable spares must be available to immediately (and automatically) replace any array disk that fails. Spares should be tested regularly to assure that they are working properly. We recommend that you test all spares daily. You can run this operation immediately by issuing a command, or you can use the Scheduler function to set up a recurring check of all the spares at a time when few, if any, users are logged on to the server.



Note: Adaptec CI/O Management Software automatically sets up a daily Test All Spares operation on the server. We recommend that you leave this default setting.

Follow these steps to test all spares:

- 1 Select **Configuration** from the View menu. The Storage Configuration window appears.
- 2 Click the icon of any spare on the right side of the dialog box. The Operations button becomes active.
- 3 Click **Operations**.
- 4 When the Spare Operations dialog box appears, click the



button. The Scheduler dialog box appears, as shown in Figure 6-2 on page 6-8.

- 5 Select **Immediate** if you want to test all spares immediately, or select **Scheduled** if you want to schedule the operation for a later time.
- 6 If you select **Scheduled**, enter a starting time, starting day, and other information.
- 7 Select an Execution Priority - **high**, **medium**, or **low**.
- 8 Click **OK** to start the operation (if you selected Immediate) or to enter it on the list of scheduled activities.
- 9 When the confirmation message appears, confirm that you want to test the spares.
- 10 Read the pop-up message that appears when the test is completed. (The message is also recorded in the server Historic Event Log and the Server View window.) If any spares failed the test, look at the Spare Disk icons in the Storage Configuration window. The icons of the failed disks will look like this .
- 11 Replace any failed disks immediately with good disks of at least the same capacity.

Blinking the Spare Drive Light

You can issue a command to blink the drive light of a spare. This allows you to see which physical drive is the actual spare.

Follow these steps to blink the drive light of a spare:

- 1 Select **Configuration** from the View menu. The Storage Configuration window appears.
- 2 Click a Spare icon in the right side of the dialog box. The Operations button becomes active.
- 3 Click **Operations**.
- 4 When the Spare Operations dialog box appears, click the  button.
- 5 Look at the array enclosure to see which disk light is blinking.

- 6 Click **Unblink all** in the Storage Configuration window to stop the drive light from blinking.

Performing Disk Operations

You can perform the following disk operations with a single disk or with a selected disk in an existing array:

- *Blinking the Drive Light* on page 6-15
- *Downing the Drive* on page 6-16
- *Pausing I/O to an Array Disk Drive* on page 6-17

Blinking the Drive Light

You can issue a command to blink the light of a disk whose icon you have selected. This allows you to see which physical disk corresponds to the Disk icon.



Note: Adaptec CI/O Management Software does not support blinking the drive lights on CD-ROM drives.

Follow these steps to blink a drive light:

- 1 Select **Configuration** from the View menu. The Storage Configuration window appears.
- 2 Click a Disk icon in the left side of the window. The Operations button becomes active.
- 3 Click **Operations**.
- 4 When the Drive Operations window appears, click the  button.
- 5 Look at the array enclosure to see which disk light is blinking.
- 6 Click **Unblink all** in the Storage Configuration dialog box to stop the drive light from blinking.

Downing the Drive

Use this option to stop all data I/O to a member of an array. You might need to use this option if the disk generates a S.M.A.R.T.¹ alert indicating that it is about to fail. When you down an array member, a spare is activated immediately (if available) to replace it, and a reconstruct is triggered for RAID levels that support it.



Note: The Down a Drive command can be used only for array members, not for spare disks or single disks.

Follow these steps to down a disk:

- 1 Select **Configuration** from the View menu. The Storage Configuration window appears.
- 2 Select the icon of the disk you want to pause.
- 3 Click **Operations**.
- 4 When the Drive Operations dialog box appears, click the  button. If a spare is available, it replaces the downed disk immediately and a reconstruct of the array is triggered.
- 5 Wait until the Reconstruct operation is complete, then continue with your work in the program.

For more information, see *Replacing an Active Array Member* on page 9-4.

¹ S.M.A.R.T. stands for Self-Monitoring Analysis and Reporting Technology. Hard drives that support this technology continually analyze their performance and generate an alert if they determine that the disk is likely to fail in the next few hours. Adaptec CIO Management Software generates an event notification if it receives this alert, allowing you to replace the disk before it actually fails.

Pausing I/O to an Array Disk Drive

Use this option to pause data I/O on a disk drive that is connected to an Adaptec RAID product. You can use this option to replace the disk if the array enclosure does not support hot swapping¹. See the array enclosure documentation for more information. When you pause I/O to a disk drive, *all* other devices connected to the Adaptec RAID product are paused as well. I/O resumes automatically at the end of the pause period.



Caution: Pause I/O cannot assure the same level of protection from electrical noise that you have when you replace a disk in an enclosure that supports hot swapping. Every time you use this feature, you should only perform one action—either disconnecting a drive or inserting a drive, but not both. *Do not* replace a non-downed drive in a paused array, as this may cause data to be corrupted. Instead, down the drive first and then replace it.

Follow these steps to pause data I/O to a disk drive:

- 1 Select **Configuration** from the View menu. The Storage Configuration window appears.
- 2 Select the icon of the disk you want to pause.
- 3 Click **Operations**. When the Array Operations dialog box



appears, click the button.

- 4 When the Pause I/O dialog box appears, enter a pause interval that does not exceed the maximum allowable pause period, and click **OK** to pause the disk. (You may need to enter the server.)

¹ *Hot swapping* support means that the array enclosure electrically isolates the bad disk's SCSI connector from the SCSI bus while the disk is being swapped to prevent data corruption. Data can still be transferred to and from the remaining good disks while the bad drive is replaced.



Note: The minimum pause period is 5 seconds; the maximum pause period is 120 seconds. The Pause I/O command is disabled if a Verify, Reconstruct, or Initialize operation is running.

- 5 Complete your work before the pause period expires. I/O resumes automatically at the end of this period.



Caution: You must replace a device with the same kind of SCSI device. You should *not*, for example, replace a disk drive with a CD-ROM drive while I/O is paused.





Scheduling and Monitoring Array Operations

Adaptec CI/O Management Software enables you to schedule certain kinds of operations to run at a later time, or to schedule them to run at regularly recurring intervals. You create these as scheduled jobs at the time you give the command to run the activity, as described in *Verifying Array Integrity* on page 6-7, *Reconstructing an Array* on page 6-2, and *Testing All Spares* on page 6-13.

Setting Scheduling Options

The Scheduler dialog box allows you to schedule the Reconstruct an Array, Verify Integrity of Array, and Test All Spares operations. Reconstruct an Array is a one-time event for which you can enter a date and time. Verify Integrity of Array and Test All Spares can be scheduled as hourly, daily, or monthly recurring events.



Caution: All scheduled activities must be deleted and rescheduled if you change the system time. Otherwise, the scheduled activities may not run at the specified time. *Do not* change the system time while Adaptec CI/O Management Software is running. Instead, stop all CI/O components and RPC modules, change the system time, and then restart CI/O.

Follow these steps to set scheduling options for a newly added operation:

- 1 Define a new scheduled operation: Reconstruct an Array, Verify Integrity of Array, or Test All Spares. The Scheduler dialog box appears, as shown in Figure 7-1.

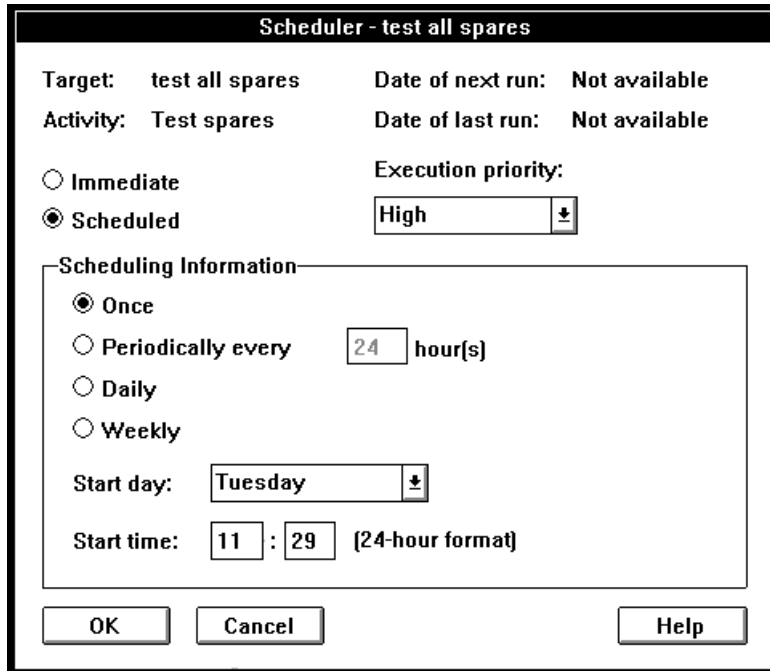

Figure 7-1. Scheduler Dialog Box

- 2 Select **Immediate** to perform the action immediately or **Scheduled** to schedule it for later.
- 3 If you select **Scheduled**, select **Once**, **Periodically**, **Daily**, or **Weekly**. Enter other information such as day of the week or start time/date, as required.

If you are scheduling an array reconstruct, you can only select the **Once** option.



Note: If you schedule an activity from a remote client to occur on a server in a different time zone, the activity will occur at the stated time relative to the server's time zone. For example, suppose you schedule an activity to occur at 11:00 P.M. on a server in a time zone that is three hours later than the remote client's time zone. The activity will occur at 11:00 P.M. in the server's time zone, which is 8:00 P.M. in the remote client's time zone.

- 4 Click **OK** to record the scheduling options. You may be prompted to confirm the activity.

Viewing and Managing Scheduled Activities

You can view information about scheduled and currently running activities in the Array Activity Monitor window. You can abort activities that are running or delete scheduled activities. The Array Activity Monitor window shows scheduled tasks for the *currently selected server*. To view activities on another server, select the Server's icon in the Server View window and open a new Array Activity Monitor window.



Note: Adaptec CI/O Management Software automatically sets up a daily Test All Spares operation on the server.

Follow these steps to view and manage scheduled activities:

- 1 Select **Activities** from the View menu. The Array Activity Monitor window appears, as shown in Figure 7-2.

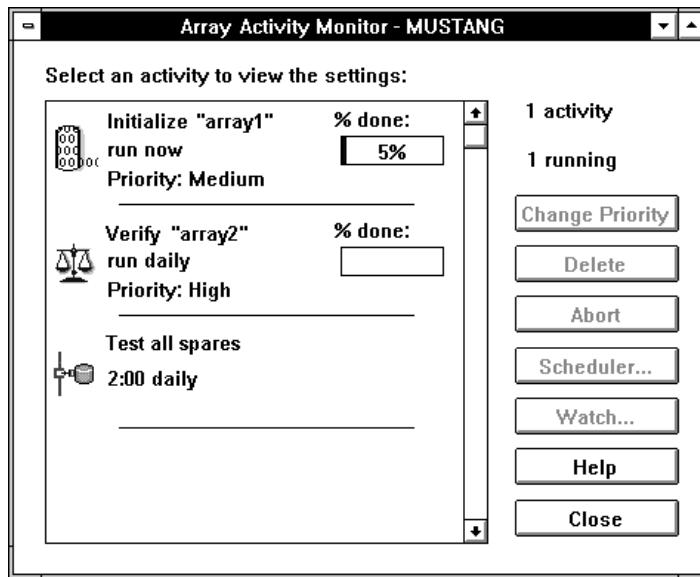

Figure 7-2. Array Activity Monitor Window

- 2 Select an Activity icon from the left part of the window. Information about the activity is shown in the window. Each kind of activity has a unique icon. The icon labels indicate which array or spare the activity applies to.

To view more detailed information about the activity, double-click the **Activity** icon. The Scheduler dialog box appears, as shown in Figure 7-1. Click **Cancel** to close the dialog box.

- 3 To change the priority of a Verify or Reconstruct operation that is currently running (as indicated by a moving icon), select the activity icon on the left of the window and then click **Change Priority**. When the Change Priority dialog box appears, select an option and click **OK**.



Note: The priority change applies only while the activity is running this time. If it is a regularly scheduled activity, the next time it runs it will have the priority originally assigned to it. You cannot change the priority of an Initialize or Test all Spares operation that is currently running.

- 4 To delete an activity that is *not* currently running, select its icon and click the **Delete** button. After you confirm the command, the activity is deleted from the list.
- 5 To abort a currently-running activity, select its icon and click the **Abort** button. After you confirm the command, the activity stops running immediately. If this is a regularly recurring activity, such as a nightly test of all spares, it will run again in the future at the next scheduled time. Use **Abort** and then **Delete** if you want the activity to never run again.
- 6 Click the **Watch** button to open a small window to monitor the selected, currently running activity. See the following section for more information.

Monitoring Activities That Are Running

You can open one or more Watch windows to monitor currently-running array activities. You can leave these small windows open while you continue doing other work on the computer.

When a Verify operation completes, the Watch window shows the total number of mismatches. A *mismatch* occurs when the parity information on a RAID 5 array does not match the user data or when some part of the data on a mirrored disk pair in a RAID 0/1 or RAID 1 array does not match. If you checked the **Auto Fix** box in the Verify dialog box, the mismatches are automatically fixed.

Follow these steps to monitor activities that are running:

- 1 Select **Activities** from the View menu. The Array Activity Monitor window appears.
- 2 Select the icon of a currently-running activity from the scrollable list at the top of the window.
- 3 Click **Watch**. A small Watch window for this activity appears, as shown in Figure 7-3. Each window has a percent complete graph and a Status field (OK or Failed). If a Verify operation is running, there is also a field listing the number of mismatches found. Click **Close** to close the Watch window after the activity has completed.

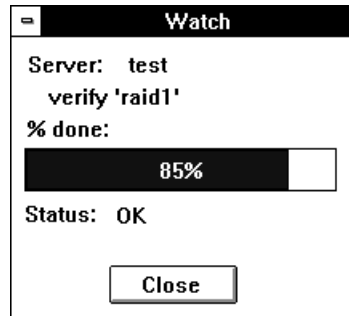

Figure 7-3. Watch Window



▼▼▼▼ 8

Setting Security Options

Adaptec CI/O Management Software provides simple but effective password protection to prevent unauthorized changes to array configuration. Users who know the password can view server information *and* can issue commands to add and delete arrays, add and delete spares, and make other changes to array configuration. Users who do not know the password can view server information but cannot change array configuration. The network administrator can disable the Guest Access feature (see page 8-4) for each server to prevent users who do not know the password from even viewing server information.

The network administrator sets the initial password for each server and controls users' access to passwords.

Changing the Password

The Server Manager allows you to change password from any client on the network.

Follow these steps to change the Adaptec CI/O Management Software password:

- 1 Open the Server View window by clicking the  button. Then select the icon of the server whose password you want to change.
- 2 Select **Server Administration** from the View menu. Then select **Change Password**. The Change Password dialog box appears, as shown in Figure 8-1.

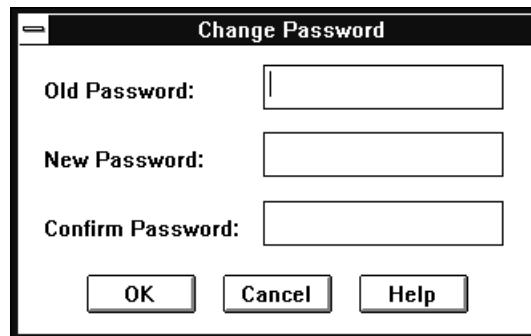

Figure 8-1. Change Password Dialog Box

If you are installing a password for the first time, type the default password, "adaptec" in the Old Password field (password is case sensitive).



Note: It is a good idea to change from the default password as soon as possible, to prevent unauthorized users from entering the Adaptec CI/O Management Software program.

- 3 Type the new password in the New Password field.

Passwords are case sensitive and can be up to 16 characters long, including the characters A-Z, a-z, and 0-9. Spaces are not allowed. Long passwords with a mixture of numerals and letters provide better security. *Do not* use obvious passwords like your name, the name of a family member, your birthday, your social security number, etc.

- 4 Type the new password again in the Confirm Password field.
- 5 Click **OK** to accept the new password.

Setting Password Time-out Options

The Password Time-out options allow you to control the way in which users are prompted to enter the server's Adaptec CI/O Management Software password when they issue commands to change a server's array configuration. The Password Time-out options are set individually for each networked client.

Follow these steps to change the Password Time-out options:



- 1 Click the  button on the toolbar. The Preferences dialog box appears.
- 2 Select one of the three password time-out options listed on the right of the dialog box. Here is a description of the options:
 - **No Password Time-out:** Requires you to enter the password only the *first time* (during each session) that you issue a command to change array configuration. This option provides somewhat less security than the others: if you leave your workstation unattended after entering the password, another person can issue commands from the workstation without being prompted for the password.
 - **Always Require Password:** Requires you to re-enter the password *every time* you issue a command to change array configuration.
 - **Enter Password Time-out Interval:** Requires you to re-enter the password at the stated time-out interval, whenever you issue commands to change the array configuration. For

example, suppose that the time-out interval is 10 minutes. You start the program at 9:00 and issue a command to create a new array on a server. You are prompted to enter the password before the command is accepted. After entering the password, you issue a command at 9:05 to add spares to the spare pool; no password is required. At 9:16 you issue a command to delete an array; since you are beyond the 10-minute interval, you are prompted again to enter the password before the command is executed.

- 3 Click **OK** to accept the password time-out change. You may be required to enter the password in order to confirm the change.



Note: You must enter the password at least once after the application has started, or when the setting has changed.

Controlling Guest Access

The Guest Access feature lets the network administrator control who is allowed to view information about the server configuration. Guest Access is enabled or disabled for each individual server. The Guest Access setting affects all users who attempt to view server information from networked clients. Here is how Guest Access works:

- When Guest Access is *Enabled* (the default), users who do not know the Adaptec CI/O Management Software password can view server information from a networked client connected to that server but cannot issue commands to change the server configuration.
- When Guest Access is *Disabled*, users who do not know the Adaptec CI/O Management Software password cannot view server information from a networked client or issue commands to change the server configuration. However, users can still view event notifications generated by servers that are on that client's server list. Users who know the password can view



server information by double-clicking the icon and entering the password.



Note: If you *do* know the server's password you can perform array operations such as Creating and Deleting Arrays whether Guest Access is enabled or disabled.

Follow these steps to enable or disable Guest Access:



- 1 Open the Server View window by clicking the  button. Then select the icon of the server whose Guest Access setting you want to change.
- 2 Select **Server Administration** from the View menu. Then select **Guest Access**.
- 3 When the Enable/Disable Guest Access dialog box appears, select or deselect the **Enable Guest Access** check box.
- 4 Click **OK** to enter the change. Enter the Adaptec CI/O Management Software password when you are prompted to do so.

The Guest Access setting is changed on the server.



|

—

|

—

|

—

|

—

...9

Managing Arrays and Spares

This chapter explains what to do when you need to replace a failed drive, physically reconfigure the disks in your server, and perform other tasks.



Note: These steps apply to devices connected to array controllers only, and do not apply to SCSI adapters.

Responding to a Critical Array

A fault-tolerant (RAID 1, RAID 0/1 or RAID 5) array enters Critical status if one disk in the array fails. The array continues to operate normally, but you may lose data if a second disk in the array fails before the array is reconstructed. (RAID 0/1 arrays can continue operating in Critical status even if two or more disks fail, as long as at least one disk in each mirrored pair remains operational.)



If a spare disk is available, the array management software will reconstruct the Critical array automatically. When the reconstruct is complete, the array returns to Fault-tolerant status. If no spare disk is available, you should respond immediately to minimize the possibility of data loss. The most effective strategy is prevention: be sure that arrays are always protected by a spare pool or by dedicated spares!

In addition, you should monitor the status of arrays at all times with Adaptec CI/O Management Software to detect arrays whose status

is Critical. You can monitor arrays effectively by enabling the Popup Event Notification option so that a message appears on the screen whenever an array enters Critical status. You can also tell that an array is in Critical status if its icon in the Storage Configuration

window looks like this .

Follow these steps to return a Critical array to Fault-tolerant status:

- 1 Click the Array icon  and observe the Disk icons of the array members on the left of the screen. One of the icons should look like this , indicating that the disk has failed.

- 2 Click the  icon and then click **Operations**.

- 3 When the Drive Operations window appears, click the



button to blink the drive light on the failed disk.

- 4 Observe which drive light is blinking. This is the disk that you need to replace. If no lights are blinking, this could mean one of the following:

- a The disk is still connected but has failed so badly that it cannot respond to the Blink command. Try blinking the drive lights of the array disks that have not failed. You may be able to determine by a process of elimination which disk has failed.
- b The disk has been removed or its power cord or SCSI cable has been disconnected.

If an array disk has been disconnected or removed but the server has not been rebooted, the icon for this disk will still appear in the Storage Configuration window. If you know that the disk was disconnected accidentally and has not actually failed, reconnect the drive and resume I/O to the array.

If the server has been rebooted since the disk was disconnected, the disk will not appear. To determine if a disk is “missing” from an array, double-click the Array icon, and read the Status field at the top of the Array Information dialog box. If this field says Missing member, a disk is missing from the array.

- c** The disk does not have an LED that indicates I/O activity.
- 5** If the array enclosure does not support hot swapping¹, pause I/O to the array before you continue. (Skip this step if the array enclosure supports hot swapping.)
- 6** Replace the failed disk with a good disk, or replace the missing disk. Be sure to complete this step before the pause period expires.
- 7** After I/O resumes automatically, select the icon of the new disk, and issue a Create a Spare command.
- 8** When the spare has been created, select the Array icon and issue a Reconstruct command, if necessary (it is possible that the reconstruct will start automatically at this point).

When the reconstruct is completed the array is in Fault-tolerant

status again, and the array icon will look like this 

Replacing a Spare

Follow these steps to replace a spare drive that is recognized as good by Adaptec CI/O Management Software:

- 1** Delete the spare (see *Deleting a Spare* on page 4-18).
- 2** If the spare is in an enclosure that supports hot swapping, remove the spare disk drive and replace it with another disk drive. Then skip to step 6.
- 3** If the spare is *not* in an enclosure that supports hot swapping, pause I/O (see *Pausing I/O to an Array Disk Drive* on page 6-17).

¹*Hot swapping* support means that the array enclosure electrically isolates the bad disk’s SCSI connector from the SCSI bus while the disk is being swapped to prevent data corruption. Data can still be transferred to and from the remaining good disks while the bad drive is replaced.

- 4 Remove the spare and allow I/O to resume.
- 5 Pause I/O again, insert the replacement drive, and allow I/O to resume.
- 6 Use Adaptec CI/O Management Software to mark the new disk drive as a dedicated spare or a pool spare (see *Creating Dedicated Spares or a Spare Pool* on page 4-15).

Follow these steps to replace a spare drive that is recognized as



down by Adaptec CI/O Management Software. (This rarely occurs. Usually, if a spare disk fails a regular test of spares, CI/O automatically deletes the spare disk.)

- 1 If the down spare is in an enclosure that supports hot swapping, remove the spare disk drive and replace it with another disk drive. Then skip to step 5.
- 2 If the spare is *not* in an enclosure that supports hot swapping, pause I/O (see *Pausing I/O to an Array Disk Drive* on page 6-17).
- 3 Remove the spare and allow I/O to resume.
- 4 Pause I/O again, insert the replacement drive, and allow I/O to resume.
- 5 Use Adaptec CI/O Management Software to mark the new disk drive as a dedicated spare or a pool spare (see *Creating Dedicated Spares or a Spare Pool* on page 4-15).

You may need to low-level format the spare disk that you removed before you can re-use it.

Replacing an Active Array Member

Follow these instructions if you want to remove an array member of a RAID 1, RAID 0/1, or RAID 5 array that has not actually failed and replace it with another disk drive. You may want to do this if the drive has generated a S.M.A.R.T. predictive failure alert.

- 1 Perform a Down operation on the array member you want to replace (see *Downing the Drive* on page 6-16).
- 2 If the array member is in an enclosure that supports hot swapping, remove it and replace it with another disk drive. Then skip to step 6.

- 3 If the array member is *not* in an enclosure that supports hot swapping, pause I/O (see *Pausing I/O to an Array Disk Drive* on page 6-17).
- 4 Remove the disk drive and allow I/O to resume.
- 5 Pause I/O again, insert the replacement drive, and allow I/O to resume.

The data from the array member will be reconstructed on the new disk drive. If a spare disk was already available, the reconstruct operation was begun automatically when you downed the array member.

Responding to an Off-Line Array

You can tell that an array is in off-line status if OFFLINE appears in the Array Status field in Adaptec CI/O Management Software for NetWare or if the Array icon in the Storage Configuration window



looks like this: . There are several reasons for an array going off-line, as described below:

- A second disk in a Critical RAID 5 array has failed, or both disks of a mirrored pair in a RAID 1 or RAID 0/1 array have failed.

If this happens, delete the off-line array, create a new array, and restore the data from your most recent backup. You cannot recover the array data if a second disk fails.

- You were trying to replace a failed disk in a Critical RAID 1, RAID 0/1, or RAID 5 array, but you mistakenly pulled the wrong disk out of the array enclosure.

If this happens, reinsert the drive you mistakenly removed and issue the Reactivate Array command, which returns the array to Critical status. Then replace the correct disk, down the server, reboot, and reconstruct the array.

- A cable to a good disk in a RAID 5 array accidentally became disconnected, and the array already had one failed drive; or a cable to a good drive in a RAID 1 or RAID 0/1 array accidentally became disconnected, and the other disk of the mirrored pair had already failed.

If this happens, reconnect the cable, and use the Reactivate Array command to return the drive to Critical status. Then replace the failed disk and reconstruct the array.

Notes on Replacing Disk Drives

Some of these notes apply only to the ARO-1130SA and AAA-13xSA adapters, not to bridge controllers (see the list of devices on page 1-1.)

- We recommend that if you use hot-swapping to replace a drive that supports tagged command queuing (TCQ), you replace it with a drive that also supports TCQ. Otherwise, a rescan operation may not detect that the drive has been swapped. Also, a system hang may occur if the replaced drive does not support TCQ and the system sends commands with tags to it. This problem will not occur if you swap drives while the server is down or while it is turned off.
- To minimize the possibility of data corruption, we recommend that when you replace a disk drive you use a new drive of the same capacity or larger.
- You must replace a device with the same kind of SCSI device when you are using Pause I/O. You should *not*, for example, replace a disk drive with a CD-ROM drive while I/O is paused.
- When you replace a failed array member with a good disk drive with the same SCSI ID, information about the new array member is not written to the array members' reserved sectors until a manual Reconstruct command is issued after the system is rescanned.
- We recommend that you remove old or defective disk drives from the system as soon as possible. You must low-level format a removed drive before you can use it again.
- A single disk cannot be replaced with a previously-used array member and be reported back to the operating system and the application layer properly. This means that if there is a channel failure, you cannot replace a single disk with an array member to make the array configuration complete and usable again while Adaptec C/I/O Management Software is running.

Optimizing Array Performance

If your Adaptec RAID product has multiple channels, you may be able to achieve better sequential data access when creating large arrays on powerful, high-end servers if some array members are connected to each channel.

The array management software and drivers allow you to use disks of various sizes and makes in the same array. To achieve the best performance, however, we recommend that you use disks of the same capacity and same model in an array. (If you use drives of different sizes, the amount of capacity actually used on each disk will be equivalent to that of the smallest disk in the array: For example, if you use five 1-GByte drives and one 500-MByte drive, only 500 MBytes on each disk will be used.)

You can also optimize array performance by selecting a RAID level for the array that best meets your needs for data reliability, read/write performance, and capacity use. See the following section for more information.

Selecting a RAID Level for an Array

The term RAID means Redundant Array of Independent Disks. An array is a grouping of disks that, by means of array management software, appears to the computer's operating system as one large disk. Part of the storage capacity of most kinds of arrays contains redundant information about the user data on the array¹. If an array disk fails, the contents of the disk can be regenerated on a new disk from the redundant information on the other array disks.

Compared with single disks, arrays can provide one or more of these desirable properties:

- improved Read and Write performance by striping data across the disks in the array. This allows data to be read from or written to two or more disks simultaneously.
- improved data reliability by storing redundant data to regenerate a failed array disk, as described above. This is especially important for servers, where arrays are most often used to store large amounts of mission-critical data.

¹ RAID 0 arrays, which do not store redundant data, are an exception to this definition.

- improved capacity utilization by allowing you to manage a large number of disks as if they were one large disk. This makes it easier to back up data, create directories, etc.

All disks of an array (including spares) must be connected to the same Adaptec RAID product, though they can be connected to different channels. You can create dedicated spare disks for each RAID 1, RAID 0/1, and RAID 5 array. You can also create a pool of spares that can be used by any RAID 1, RAID 0/1, or RAID 5 array on the Adaptec RAID product.¹

The array management software and firmware support RAID 0, RAID 1, RAID 0/1, and RAID 5 arrays. The advantages, disadvantages, and requirements of these RAID levels are as follows:

RAID 0 Arrays

Maximum Disks Allowed: 16²

Minimum Disks Allowed: 1³

In a RAID 0 array, data is distributed, or striped, across the disks in the array. The capacity of the array is approximately equal to the combined capacity of the physical disks. The I/O performance of a RAID 0 array is much better than that of a single physical disk because multiple reads and writes can be handled in parallel and because when large files are accessed the striped data is retrieved simultaneously from several disks.

RAID 0 arrays do not store redundant data and therefore are not true RAID applications. If one disk fails, the entire array fails and all data is lost. This means that the fault tolerance of a RAID 0 array is less than that of any single disk in the array. The term RAID 0 is widely used for these arrays, however, because they are conceptually similar to true RAID applications.

¹ A disk in a spare pool can only be used to replace a failed disk in an array if it is at least as large as the smallest disk in the array.

² The maximum would be 15 disks if the system has a single SCSI channel.

³ One-disk RAID 0 arrays are used only to control the virtual device order of single disks.

RAID 1 Arrays

Maximum Disks Allowed: 2

Minimum Disks Allowed: 2

RAID 1 arrays use a single pair of disks. They are called mirrored arrays because both disks in the pair contain the same data. When data is written to a RAID 1 array it is written to each disk in the pair. The read performance of a RAID 1 array can be much better than that of a single disk, while the write performance is slightly worse. Mirrored arrays are highly reliable because the data is still safe if one disk in the pair fails. They are more costly, however, because you get only one disk of actual storage capacity from the pair of disks.

RAID 0/1 Arrays

Maximum Disks Allowed: 16 (must be an even number)¹

Minimum Disks Allowed: 4

RAID 0/1 disks use from two to eight pairs of disks. They are called mirrored arrays because both disks in each pair contain the same data. The read and write performance of a RAID 0/1 array is much better than that of a single physical disk. RAID 0/1 arrays are highly reliable; the array data remains safe so long as at least one disk of each mirrored pair is good. Thus, in a 12-disk RAID 0/1 array, the array could continue working with up to six failed disks if one disk in each pair is still good. Because of the mirrored arrangement, RAID 0/1 arrays require twice as many disks as the actual amount of storage space.

¹ The maximum would be 14 disks if the system has a single SCSI channel.

RAID 5 Arrays

Maximum Disks Allowed: 16¹

Minimum Disks Allowed: 3

RAID 5 arrays contain redundant information in the form of parity data, which is calculated block-by-block for all user data. The parity data is distributed across all the disks in the array and occupies the equivalent capacity of about one disk. User data is interspersed with this parity data. If one disk in the array fails, its data can be reconstructed from the user data and parity data on the other disks. Two disks must fail before the entire array fails. The read performance of RAID 5 arrays is excellent and is comparable to that of a RAID 0 array. Write performance is slower than that of a RAID 0 array, because new parity data must also be calculated and written when user data is written.



¹ The maximum would be 15 disks if the system has a single SCSI channel.

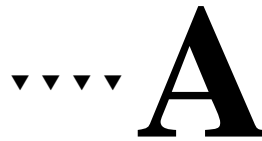

Configuration Settings

This appendix describes the configuration variables that control the appearance of the Adaptec CI/O Management Software user interface and the way in which array and system operations are carried out. The variables controlling the user interface appearance are in the Windows NT registry. The other variables are defined in the *iomgr.ini* and *cioams.ini* files

Many of the variables are configured for you once you install the software or start the program. If you are an advanced user and you want to customize your settings, you can edit the variables in the NT registry, or you can open *iomgr.ini* or *cioams.ini* in a text editor and manually make changes.

iomgr.ini

The *iomgr.ini* file is located in the directory where the Adaptec CI/O Management Software is installed on your server. The section name, for example [ARRAYOPERATIONS], and the variables under each section are described below:

[ARRAYOPERATIONS]

Re-createPriority=

This variable specifies the priority of the automatic Re-create operation. Valid values are Low, Medium, or High. The default is *Medium*.

VerifyIfDirty=

This variable specifies whether you want to start the Verify operation if the array is dirty (meaning that the array was not shut down properly). Valid values are Yes or No. The default value is *No*.

DriverMonitoringFrequencyInSecs=

This variable specifies the maximum interval in seconds before Adaptec CI/O Management Software polls the driver. Any number of seconds can be specified; small values affect performance, large values (greater than 10 seconds) affect responsiveness to problems. The default value is 5.

[SYSTEM]

PauseEnabled=

This variable specifies whether the Pause I/O capability is enabled or disabled. Valid values are Yes and No.

ServerLogSizeInMegabytes=

This variable is used to limit the size of the Server Log database file. The Server Log database will be truncated if it grows beyond the size specified by the parameter. The size can be specified in increments of 1 MByte, up to a maximum of 10 MBytes.

StatisticsCollectionInterval=

This variable specifies the interval at which system statistics will be collected, assuming that the driver supports statistics collection. Values must be entered as whole numbers. The default value is 1.

WarnAfterFirstPFAEvent=

If set to **Yes**, this variable specifies that if SMART events (PFA) are received from any drive the first event will be reported as a Critical event and all events after that will be reported as Warning events. If set to **No**, all SMART events will be reported as Critical. The default is *Yes*.

[TASKS]

TestAllSpares=

This variable schedules the Test All Spares operation. These jobs are not written to the Scheduler Database and are scheduled every time *iomgr.nlm* (NetWare) or *iomgr.exe* (Windows NT) is started. Valid values are

- **Yes,H**—Starts test every hour on the hour. For example, **TestAllSpares=Yes,H**
- **Yes,D,Time**—Starts test daily at a specified time (military time format). For example, **TestAllSpares=Yes,D,11:34**. (The default value is to test all spares daily at 2:00 A.M.)
- **Yes,W,Day of the week,Time**—Starts test weekly at a specified day and time (Day of the week: 0=Sun, 1=Mon, 2=Tues., etc.). For example, **TestAllSpares=Yes,W,2,11:34** (starts every week on Tuesday at 11:34).
- **No**—No tests are scheduled. For example, **TestAllSpares=No**.

[CAPABILITIES]

EnableRAID5=

This variable enables or disables the option of creating RAID 5 arrays. If it is set to **No** users cannot create RAID 5 arrays. Valid values are *Yes* and *No*. The default is *Yes*.

EnableRAID10=

This variable enables or disables the option of creating RAID 0/1 arrays. If it is set to **No** users cannot create RAID 0/1 arrays. Valid values are *Yes* and *No*. The default is *Yes*.

[ENCLOSUREMANAGER]

EnabledEnclosureInterface=SAF-TE

This variable specifies the enclosure management interfaces that are supported by CI/O. Currently, only SAF-TE is supported.

SAF-TEPollingPeriodInSeconds=

This variable specifies the polling frequency, in seconds, for SAF-TE. This is the interval at which the SAF-TE enclosure is polled to check the status of all elements of the enclosure, such as power supplies and fans. The default is 5.

cioams.ini

The *cioams.ini* file is located in the *\windows* directory. The section name, for example [CORE], and the variables under each section are described below:

[CORE]

ConfigPath=

This variable specifies the default path name for the server configuration file. (The configuration file keeps a record of the server information.) For example, `ConfigPath=configs.dat`.

[VIEW]

ServerView=

This variable specifies whether the Server View window is displayed when the program starts. Valid values are 0 (is not displayed) and 1 (is displayed). If this variable is not specified, the default is 0.

[PROTOCOL]

IP=

If set to 1, Adaptec CI/O Management Software will attempt to load IP protocol when the program starts.

IPX=

If set to 1, Adaptec CI/O Management Software will attempt to load IPX protocol when the program starts. If you are only monitoring

Configuration Settings

Windows NT servers (and you are *not* monitoring any NetWare servers) we recommend that you set this variable to 0. This change will prevent a harmless, but annoying, error message from appearing.

[RPC ICONS]

Visibility=

Set this variable to `Visibility=Hide` to hide the RPC services icons when running Adaptec CI/O Management Software on a networked client.

[HEARTBEAT]

Interval=

This variable indicates the frequency, in minutes, at which the networked client attempts to connect to the server to get updated information. The default is *10*.

Windows NT User Interface Variables

The Adaptec CI/O Management Software user interface variables are located in the Windows NT registry under *HKEY_LOCAL_MACHINE\SOFTWARE\Adaptec\Adaptec CI/O Array Management Software*. These variables apply only to the server console version of Adaptec CI/O Management Software, not to the networked client installations:

- **Config Path: REG_SZ: configs.dat**
This is the storage path for the configuration file.
- **Display Activity: REG_DWORD: 0**
If the value is non-zero, the application will display the Activity Monitor window on startup.
- **Display Config: REG_DWORD: 0x2**
If the value is non-zero, the application will display the Storage Configuration window on startup.
- **Display Server Log: REG_DWORD: 0**
If the value is non-zero, the application will display the Historic Event Log window on startup.
- **Display Server View: REG_DWORD: 0**
If the value is non-zero, the application will display the Server View window on startup. (This is not applicable to the desktop version of Adaptec CI/O Management Software.)
- **Notifications: REG_DWORD: 0**
Popup Box is 0x1, Beep is 0x2, Flash Titlebar is 0x4, and None is 0x0. These values may be OR'ed together.
- **Server Name: REG_SZ:**
- **Severity: REG_DWORD: 0xd**
Informational is 0x1, Warning is 0x4, and Critical is 0x8. These values may be OR'ed together.
- **Start Date: REG_SZ: 1/1/1990**
- **Start Time: REG_SZ: 00:00:00**

I/O Manager Settings

The behavior of the I/O Manager may be changed by entries in the *iomgr.ini* file.

I/O Manager options (ASPI Manager Extensions) are configured by entries in the standard I/O Manager initialization file (*iomgr.ini*). A section headed [ASPIMODEL] can be added to this file. The available options are as follows:

DisableASPI = [Yes | No]

This option disables all ASPI Manager functions. This option may be used for problem isolation in I/O Manager systems that contain multiple managers.

DiscoveryInterval = n

This option configures the frequency (in seconds) that the Discovery phase is run. The default value is 1800 (30 minutes). System design precludes the possibility that a Poll phase or a Statistics phase will be active when a Discovery phase is activated.

PollInterval = n

This option configures the frequency (in seconds) that the Poll phase is run. The default value is 180 (3 minutes). If a Poll phase is activated when a Discovery phase is active, the Poll phase is delayed until the Discovery phase completes. System design precludes the possibility that a Statistics phase will be active when a Poll phase is activated.

StatisticsInterval = n

This option configures the frequency (in seconds) that the Statistics phase is run. The default value is 10 (10 seconds). If a Statistics phase is activated when a Discovery phase is active, the Statistics phase is delayed until the Discovery phase completes. System design precludes the possibility that a Poll phase will be active when a Statistics phase is activated.

Lun0Required = [Yes | No]

This option tells the ASPI Manager whether LUN 0 must be present before LUNs other than 0 will be checked. A setting of Yes requires that LUN 0 be present before non-zero LUNs will be checked. The default value is *No*.

Lun0Only = [Yes | No]

This option tells the ASPI Manager whether or not to check LUNs other than 0. A setting of Yes disables non-zero LUNs. The default value is *No*, though this may vary by operating system type.

ErrorInstrumentation = [Yes | No]

This option, if Yes, enables the ASPI Manager to collect error related instrumentation from instrumentation capable drivers. The default value is *No*. If both this option and the IOInstrumentation option are set to No, then the ASPI Manager will not check for instrumentation capable drivers.

IOInstrumentation = [Yes | No]

This option, if Yes, enables the ASPI Manager to collect I/O related instrumentation from instrumentation capable drivers. The default value is *No*. If both this option and the ErrorInstrumentation option are set to No, then the ASPI Manager will not check for instrumentation capable drivers.

ResetInstrumentationOnPowerup = [Yes | No]

This option tells the ASPI Manager whether or not to issue an Instrumentation Reset to each instrumentation capable driver when the ASPI Manager initializes. The default value is *Yes*, which enables Instrumentation Resets. If both the ErrorInstrumentation and the IOInstrumentation options are set to No, this option has no effect.

ResetInstrumentationOnDiscovery = [Yes | No]

This option tells the ASPI Manager whether or not to issue an Instrumentation Reset to each instrumentation capable driver when that driver is newly discovered. The default value is *Yes*, which enables Instrumentation Resets. If both the ErrorInstrumentation and the IOInstrumentation options are set to No, this option has no effect.

SMARTPolling = [Yes | No]

This option tells the ASPI Manager whether or not to check whether SCSI devices support Predictive Failure Analysis, and if so to monitor them for SMART events. The default value is *Yes*, which enables SMART support.

SMARTTest = [Yes | No | testcount]

This option tells the ASPI Manager whether or not to enable Predictive Failure Analysis test mode. For debugging purposes, SMART capable devices internally have a test bit which allow them to generate SMART events even when the hardware is not having a problem. The default value is *No*, which does not enable any SMART debug events. Choosing option *Yes* turns the SMART debug bit on for all SMART capable devices and leaves it on. Providing a count instead of *Yes* turns the SMART debug bit on until at least count debug events are seen, then the SMART debug bit is turned back off. More than the requested count of debug events may be generated before the software can turn all debug events off. This option has no effect if SMARTPolling is set to *No*.

ForceHAWide16 = [Yes | No]

ForceHAWide32 = [Yes | No]

These two options are used to override the information obtained from the operating system driver about whether or not host adapters support Wide SCSI. These switches are especially useful with older drivers that do not report to ASPI whether or not a host adapter supports Wide SCSI. The default value for both switches is *No*, which forces ASPI to rely upon operating system driver information. If ForceHAWide16 is set to *Yes*, then all host adapters are assumed to support at least 16-bit Wide SCSI. If ForceHAWide32 is set to *Yes*, then all host adapters are assumed to support at least 32-bit Wide SCSI.

If an operating system driver reports that a host adapter supports 32-bit Wide SCSI when ForceHAWide16 is set to *Yes*, then that host adapter will still be treated as a 32 bit Wide SCSI device. In other words, these switches may “widen” a host adapter, but will never make it “narrower” than the operating system driver reports.

The switch values are only applied when a host adapter is discovered; if a host adapter already exists in the device database then these switches have no effect upon that host adapter or upon subsequently added devices. Therefore, the device database should usually be cleared after changing these switches.



Note: Using these switches has the potential to cause ASPI to attempt I/O to a SCSI ID which cannot exist if a host adapter is forced wider than it is in reality. As the results of doing so are not predictable across all driver/operating system combinations, these switches should be used with care.

AccessibleDrivers = [* | comma delimited list of driver names]

This option controls which operating system drivers (and therefore which host adapters) will be managed by the ASPI Manager. The drivers are identified by the driver name returned when the ASPI Manager performs a host adapter inquiry. The names specified are inclusive – if a driver name does not appear in the list, then the ASPI Manager will ignore all host adapters which are accessed through that driver.

This option is especially useful when the I/O Manager includes multiple manager support, for example simultaneous SCSI and RAID host adapters. The ASPI Manager can be informed through this option to leave the management of the RAID host adapters to the RAID Manager. The option can also be used to inform the ASPI Manager to ignore any drivers that may cause problems, such as third-party device drivers.

The * syntax is used to specify that all host adapters are accessible. If the line:

```
AccessibleDrivers = *
```

appears in the *.ini* file, then the ASPI Manager will manage all host adapters it discovers.

The comma delimited list of driver names specifies, by name, which drivers will be managed by the ASPI Manager. The names are treated as prefixes. For example, specifying a name of AIC will allow the ASPI Manager to manage all host adapters whose driver names begin with the three character sequence AIC. The name may be specified in as many characters as the user wishes, so that the list might specify either a family of drivers or a specific driver. The names specified are not case sensitive.

The default is to manage all drivers beginning with AIC and AHA (although the driver names vary somewhat from system to system).

Configuration Settings

The default allows popular Adaptec host adapters, such as the AHA-1540 and AHA-2940, to be managed by the ASPI Manager. The default is equivalent to the *.ini* specification:

```
AccessibleDrivers = AIC, AHA, ADAPTEC AIC, ADAPTEC  
AHA, ADPT AIC, ADPT AHA
```

Note that putting an asterisk anywhere in the names makes all the other names meaningless. The specification:

```
AccessibleDrivers = AIC, *
```

would cause all drivers to be accessible, not just AIC drivers.

Up to 100 drivers may be specified, and the maximum length of the string of driver names is 255 characters. The names specified in the `AccessibleDrivers` statement may differ for different operating system platforms.

Drivers are only checked for accessibility when a host adapter is discovered; if a host adapter already exists in the device database then this option has no effect upon that host adapter or upon subsequently discovered devices on the host adapter. Therefore, the device database should usually be cleared after changing this option.



|

—

|

—

—

|

|

—



SAF-TE Enclosure Management

Adaptec CI/O Management Software provides easy management of SAF-TE enabled enclosures. Enclosures that support SAF-TE provide a standard, non-proprietary way for third-party disk and RAID controllers to be fully integrated with peripheral packaging that supports status signals (LED's, audible alarm, LCD, etc.), hot swapping of hard drives, and monitoring of enclosure components.

Features of SAF-TE

The following features are supported by Adaptec CI/O Management Software:

- **Detecting Enclosures:**

For all enclosures connected to SCSI, as well as RAID controllers, an event is generated identifying the address of the enclosure. Also, when you double-click on a channel icon, the device count that is displayed is incremented to include the enclosure.

- **Checking Enclosure Status:**

CI/O Management Software periodically checks the status of all elements (disks, power supplies, temperature, fans, etc.) of all connected SAF-TE enclosures and generates associated events. These events can be viewed through the event log. CI/O Management Software also takes the following actions:

Adaptec CI/O Management Software User's Guide

- **Reflecting the status on the enclosure:** CI/O Management Software takes the appropriate action—changing the state of LEDs on the enclosure, setting alarms, etc.—when it detects statuses such as power supply failure or temperature out of range.
- **Insertion/Removal of devices:** CI/O Management Software detects insertion and removal of devices from the enclosure and generates appropriate events. The configuration is updated so that the inserted/removed device is reflected in the CI/O Configuration window.

If the removed drive is a SINGLE, CI/O Management Software automatically starts the Rescan operation. If the removed drive is an array member, CI/O automatically starts the array reconstruct operation, provided that at least one dedicated spare or pool spare is available.

Description of Events

Adaptec CI/O Management Software identifies events related to each SAF-TE enclosure. Each enclosure is identified by a unique address (bus/host adapter, channel, SCSI ID, and LUN). This address is specified for all events logged for that particular enclosure, to allow easy identification of the enclosure.

The following is a complete list of all events that may be generated for SAF-TE enclosures:

- 1** *Enclosure found [SAF-TE: unique address]*— For each found and successfully initialized SAF-TE enclosure, an event identifying the unique address is generated.
- 2** *Enclosure not responding [SAF-TE: unique address]*— For each unrecoverable error that occurred when communicating with a SAF-TE enclosure. CI/O Management Software stops polling this device until communication is recovered. On recovery, monitoring of this device starts automatically.
- 3** *Enclosure removed from bus [SAF-TE: unique address]*— Posted when an enclosure device is removed from the bus (for example, it was physically removed, power was switched off, etc.).
- 4** *Device id=SCSI_ID slot#=slot_number inserted [SAF-TE: unique address]*— When a device is inserted into a SAF-TE enclosure slot, this event is posted. CI/O Management Software automatically performs a rescan on the controller to which the SAF-TE enclosure is attached.
- 5** *Device id=SCSI_ID slot#=slot_number removed [SAF-TE: unique address]*— Posted when a device is removed from a SAF-TE enclosure slot. If the removed drive is a SINGLE, CI/O Management Software automatically performs a rescan. If the removed drive is an array member, CI/O automatically starts a reconstruct, if there is at least one dedicated spare or pool spare.

6 For each change in the status of a cooling fan or temperature, a new status may be posted:

- a** *Fan #fan_number is malfunctioning [SAF-TE: unique address]*
- b** *Fan #fan_number is removed [SAF-TE: unique address]*
- c** *Fan #fan_number is in an unknown state [SAF-TE: unique address]*
- d** *Temperature is out of normal range, sensor #sensor_number [SAF-TE: unique address]*
- e** *Overall temperature is out of normal range [SAF-TE: unique address]*

CI/O Management Software attempts to spin up all other fans to maximum capacity to avoid possible overheating. As a result of this action, the following two events may be posted:

- *Fans are running at maximum capacity [SAF-TE: unique address]*
 - *Fan speed increase to maximum capacity has failed [SAF-TE: unique address]*
- f** *Fan #fan_number is operational [SAF-TE: unique address]*
 - g** *Overall temperature is in normal range [SAF-TE: unique address]*

CI/O Management Software attempts to slow down cooling fans. As a result of this action the following two events may be posted:

- *Fans are running at half capacity [SAF-TE: unique address]*
- *Fan speed decrease to half capacity has failed [SAF-TE: unique address]*

SAF-TE Enclosure Management

- 7** For each change in the status of the power supplies connected to the enclosure, one of the following event notifications may be posted:
- a** *PowerSupply #power_supply is operational and OFF [SAF-TE unique address]*
 - b** *PowerSupply #power_supply is operational and ON [SAF-TE unique address]*
 - c** *PowerSupply #power_supply is malfunctioning and OFF [SAF-TE unique address]*
 - d** *PowerSupply #power_supply is malfunctioning but ON [SAF-TE unique address]*
 - e** *PowerSupply #power_supply is present [SAF-TE unique address]*
 - f** *PowerSupply #power_supply is not present [SAF-TE unique address]*
 - g** *PowerSupply #power_supply is in unknown state [SAF-TE unique address]*
- 8** For each change in the status of the door lock of the enclosure, one of the following events notifications may be posted:
- a** *Door is locked [SAF-TE unique address]*
 - b** *Door is unlocked [SAF-TE unique address]*
 - c** *Speaker is present [SAF-TE unique address]*
 - d** *Speaker is not present [SAF-TE unique address]*

- 9** CI/O Management Software sets LED states of devices located inside enclosures in the following cases:
- Drive failed (failed drive is identified)
 - Predicted fault (identifies the drive for which a S.M.A.R.T. event was received)
 - Unconfigured drive (unconfigured drive is identified)

The following events are for devices connected to RAID boards only:

- Array rebuilding (all members of an array being rebuilt are identified)
- Array off-line (all members of an off-line array are identified)
- Critical array (all members of a critical array are identified)
- Array is being verified (all members of array being verified are identified)
- Hot spare (identifies a drive used as a hot spare)
- Rebuild failed (all members of array for which rebuild failed are identified)



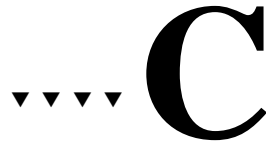

Using the *ArrayConfigSA* Initial Boot Array Installation Utility

This Appendix explains how to use the *ArrayConfigSA* Initial Boot Array Installation Utility to create and delete arrays and spare disks. You can use *ArrayConfigSA* to create a bootable array for the server. We recommend that you configure the server to boot from an array instead of from a single disk. This provides greater protection for network operating system files and data files stored on the array.

ArrayConfigSA runs from a diskette, so you can run it when the server is off-line and the operating system is not running. Nearly all *ArrayConfigSA* functions except creating a bootable array can also be performed with Adaptec CI/O Management Software, which runs under Windows.

The *Installation and Hardware Guide* for your Adaptec product has information on connecting SCSI devices, installing software, preparing to run *ArrayConfigSA*, and creating your first array with *ArrayConfigSA*. (The information on creating the first array is also included in this Appendix.)



Note: *ArrayConfigSA* is not supported for arrays on bridge adapters. See the bridge adapter *Installation Guide* for more information.

Creating an Array with ArrayConfigSA

You can create arrays with ArrayConfigSA or with Adaptec C/I/O Management Software, which is described in chapters 2 through 9 of this document. However, if you want to install the operating system on the array, you must create the array with ArrayConfigSA. The following instructions can be used to create a bootable or a non-bootable array.



Note: To select ArrayConfigSA menu options, type the *hot key*—the letter that appears in a different color. (The hot key letters are underlined in the following instructions). You can also press the ↑ and ↓ keys until the option is highlighted and then press **Enter**. If you have a monochrome monitor and the highlight bar is not visible, press **Ctrl-B** to change to monochrome mode.

- 1 Insert the copy of the ArrayConfigSA diskette in drive A of the server with the Array product and boot the server. The program will start automatically.
- 2 Select **Disk Array Operations** from the Main Menu.
- 3 Select **Create New Array** from the Disk Array Operations menu.
- 4 Type an array name and press **Enter**. The name can be up to 15 characters long and can include spaces and any other printable characters.
- 5 Select an array type from the list. Your options are
 - **RAID 0**: Data is striped across the disks in a RAID 0 array, allowing for faster I/O performance than a single disk. RAID 0 arrays do not store redundant data; if any disk in the array fails, all data is lost.
 - **RAID 1**: Data is mirrored on one pair of disks. If one disk fails, data is still safe. The actual usable data capacity of the array equals half the available disk space.
 - **RAID 5**: The array contains redundant (parity) data distributed across all disks in the array. If any one disk fails, data can be reconstructed from the parity information. If a second disk fails before the array has been reconstructed, all

Using the ArrayConfigSA Initial Boot Array Installation Utility

data is lost. The actual usable data capacity of the array is equal to one less than the total number of disks. (One disk's worth of capacity is needed to hold the parity information.)

- **RAID 0/1:** Data is striped and mirrored on two or more pairs of disks. If one disk in a pair fails, data is still safe. The actual usable data capacity of the array equals half the total available disk space.

See *Selecting a RAID Level for an Array* on page 9-7, for more information on RAID levels and RAID technology.

- 6** Type the number of drives you want in the array and press **Enter**. This number should not include *spare*s (drives that will automatically replace failed array drives). The number of drives available for assignment is listed on the screen.



Note: This step does not apply to RAID 1 arrays, which have two drives by definition.

- 7** When the next screen appears, press **Tab** to highlight a channel (if your Adaptec product has more than one channel). When the drives on the highlighted channel appear in the SCSI IDs on Channel menu, select drives for the array. To do this, press the **↑** and **↓** keys until the drive name is highlighted, and then press **Ins** or **Enter**. The names of selected drives appear to the right, in the Adaptec Array # box.

To select drives on a different channel (if necessary) press **Tab** to select another channel and then select the drives from the SCSI IDs on Channel menu. To deselect the drive you most recently added, press **Del**.



Caution: A warning appears if you select a disk that has partitions. *Do not* select disks with partitions if they contain data you want to keep, because any existing data will be erased when the disk becomes part of the array.

When you have selected the number of drives you specified in Step 6, the next screen appears automatically. If you are creating a RAID 1, RAID 0/1, or RAID 5 array, and if there are

any unassigned drives, the screen prompts you to define dedicated spare drives for the array. (We recommend that you use a *spare pool* instead of dedicated spares. See *Adding a Disk to a Spare Pool* on page C-9 for more information.)



Note: A spare must have at least the capacity of the smallest drive in the array.

- 8 If you do not want a spare, type n and continue with Step 10. If you want to select dedicated spares, follow these steps:
 - a At the prompt, type y.
 - b At the next prompt, type 1 or 2.
 - c Select one or two spares, using the same method you used to select disks for the array.
- 9 When the Initialize Mode menu appears, select **Initialize Array to Zero**. Formatting begins immediately. A graph on the screen shows the progress of this operation.



Caution: If the drives contain data, all the data is lost when you initialize the array.

Select **Low-Level Format** only if the drives were previously formatted on another system or if you think they may have surface defects. Low-level formatting takes a long time for large disk drives. (See *Initializing an Array* on page C-7 for more information.)



Note: If your disk drives initialize very slowly when you create arrays, you may be able to speed them up by changing a setting in the *arconfig.ini* file (located on the ArrayConfigSA diskette). To do this, open *arconfig.ini* in a text editor and find this line:

```
rem WriteSame=Yes
```

Delete the letters rem and save the file in text-only format. The next time you run ArrayConfigSA the disks should initialize faster.

Using the ArrayConfigSA Initial Boot Array Installation Utility

Another menu option, **Skip Initialization**, appears if you are creating a RAID 0 array. If you select this option, the RAID 0 array will be created without being initialized. Unlike the other RAID levels, RAID 0 arrays are not *required* to be initialized before they are used. However, we recommend that you do initialize RAID 0 arrays.

- 10** When the menu of block sizes appears, select a block size. (This menu does not appear if the array is a mirrored array with only two drives.)

The allowable block sizes are 8, 16, 32, 64 (the default), and 128 KBytes. The default block size gives the best overall performance in most network server environments.

- 11** When you see the message Initialization of [array name] is complete, press any key to return to the Disk Array Operations menu.
- 12** To create additional arrays (if disks are available), repeat Steps 3-10. When all arrays are created, exit from ArrayConfigSA, remove the ArrayConfigSA diskette, and reboot the computer. After you reboot you can write data to the arrays.

Making the Array Bootable

Follow these steps to make the server boot from the newly created array or to change the boot order of existing arrays:

- 1** Select **Display Boot Order** from the Main Menu. The Boot Order for Singles and Arrays window appears.
- 2** If the newly created array is at the top of the list, preceded by the words **Unit 0**, no changes are necessary; if it has some other unit number, highlight the array name and press **Enter** to select it.
- 3** Use the arrow keys to move the selected array to the top of the list. Then press **Enter** to de-select it. If you want to change the boot order of another array, select it, move it with the arrow keys, and press **Enter** again.
- 4** When you are finished, press **Esc** to return to the Main Menu.



Note: You cannot use this procedure to change the boot order of a SCSI disk drive that is not part of an array. If you want to do this, create a one-disk RAID 0 array from the disk. (Data is not actually striped on a one-disk array.)

For more important information on creating a bootable array, see the *Installation and Hardware Guide* for your Adaptec product.

Other ArrayConfigSA Options

The remainder of this chapter explains how to use the other ArrayConfigSA options. You can also create and manage arrays with the Adaptec CI/O Management Software.

Displaying Array Information

Follow these steps to display information about existing arrays on the server or workstation:

- 1 Select **Disk Array Operations** from the Main Menu.
- 2 Select **Display Arrays** from the Disk Array Operations menu.
- 3 When the list of arrays appears, highlight the array for which you want information and press **Enter**.
- 4 View the information that appears on the screen. This includes array type and status, array size, and information about each disk in the array.
- 5 Press any key to return to the Disk Array Operations menu.

Deleting an Array



Caution: All data is lost when you delete an array! Before you delete an array, back up any data you want to keep.

Follow these steps to delete an array:

- 1 Select **Disk Array Operations** from the Main Menu.
- 2 Select **Delete Array** from the Disk Array Operations menu.

Using the ArrayConfigSA Initial Boot Array Installation Utility

- 3 When the list of arrays appears, select the array you want to delete.



Caution: A warning appears if you select an array that has partitions. *Do not* delete an array with partitions if it contains data you want to keep, because any existing data will be erased. Be especially careful not to select your boot array!

- 4 View information about the array and make sure you really want to delete it. Press any key to continue.
- 5 Type y to delete the array (or n to cancel the operation).
- 6 When the message [Array name] deleted appears, press any key to continue.

The drives that were formerly part of the array can now be used as stand-alone drives or as members of another array. Deleting an array may change the boot order and the drive assignment.

Initializing an Array

When you create a new array, you are automatically prompted to initialize (format) it. You can also select the Format/Initialize Array option as a separate command, perhaps to reinitialize an array that has become corrupted.

Here is more information on the two initialization methods:

- **Initialize Array to Zero:** (Recommended method) Fills the array with zeroes. This option is faster than a low-level format, but it does not verify the integrity of the disks.
- **Low-level Format:** Performs a low-level SCSI format. This writes a consistent pattern to the disks, checks the disks for defects, and fills the array with zeroes. Low-level formatting can take a long time if the disks are large.



Caution: Formatting or initializing an array erases all data on the array and cannot be aborted once it has started. If the array contains data you want to keep, be sure to back it up first!

Follow these steps to initialize an array:

- 1** Select **Disk Array Operations** from the Main Menu.
- 2** Select **Format/Initialize Array** from the Disk Array Operations menu.
- 3** When the list of arrays appears, select the array you want to initialize.
- 4** Type **y** to confirm that you want to format the array.



Caution: A warning appears if you select an array that has partitions. *Do not* initialize an array with partitions if it contains data you want to keep, because any existing data will be erased. Be especially careful not to initialize your boot array!

- 5** When the Select Format Mode menu appears, select **Initialize Array to Zero** or **Low-Level Format**.
- 6** When the list of block sizes appears, select a block size. The allowable block sizes are 8, 16, 32, 64 (the default), or 128 KBytes. (This menu does not appear if the array is a mirrored array with only two drives.) The default block size provides the best overall performance for most applications. Formatting begins immediately.
- 7** When you see the message Initialization of [array name] is complete, press any key to return to the Disk Array Operations menu.

Creating and Deleting Spares

Spare disks (*spares*) are an important data protection and real-time recovery feature of RAID 1, RAID 0/1, and RAID 5 arrays. (RAID 0 arrays do not support spares.) If a disk in an array fails while the server is running, a spare is activated immediately to take its place. The array software automatically reconstructs the necessary data on the new disk, and array operation continues uninterrupted.

You can create one or two *dedicated spares*, which can be used only by a single specified array. We recommend, however, that you create a *spare pool* instead. The spares in a spare pool can be used as needed by *any* array connected to the same controller, if the spare is at least as large as the smallest disk in the array. A spare pool can have up to eight disks.

Adding a Disk to a Spare Pool

Follow these steps to create a new spare pool or to add a disk to an existing spare pool. You should add a disk to the spare pool whenever one of these spares is automatically used to replace a failed array member.

- 1 Select **Spare Pool Operations** from the ArrayConfigSA Main Menu.
- 2 Select **Add Device to Spare Pool** from the Spare Pool menu.
- 3 Select a channel from the list, if necessary.
- 4 Highlight a disk to add to the spare pool and press **Enter**.



Caution: A warning appears if you select a disk that has partitions. *Do not* select disks with partitions if they contain data you want to keep, because any existing data will be erased when the disk is added to the spare pool. Be especially careful not to select your boot disk as a spare!

The spare is added immediately. Press any key to return to the Spare Pool Operations menu.

- 5 Repeat Steps 2-4 to add another disk to the spare pool. Spare pool disks can be connected to any channel on the adapter.



Note: You can add a disk of any size to the spare pool, even if the disk is too small to protect the existing arrays. For example, if you have created two arrays with 1 GByte members, you can add a 500-MByte disk to the spare pool, even though this disk is too small to replace any failed array member. If you later create a third array with 500-MByte members, the smaller spare pool disk can automatically replace a failed member of that array.

- 6 When you have finished adding disks, press **Esc** to return to the ArrayConfigSA Main Menu.

Deleting a Disk from a Spare Pool

Follow these steps to delete a disk from a spare pool:

- 1 Select **Spare Pool Operations** from the ArrayConfigSA Main Menu.
- 2 Select **Delete Device from Spare Pool** from the Spare Pool menu. The disk most recently added to the spare pool is immediately deleted. Press any key to return to the Spare Pool menu.
- 3 Repeat Step 2 to delete another disk from the spare pool, if desired.
- 4 When you have finished deleting disks, press **Esc** to return to the ArrayConfigSA Main Menu.

Viewing Spare Pool Information

Follow these steps to view information about disks in a spare pool:

- 1 Select **Spare Pool Operations** from the ArrayConfigSA Main Menu.
- 2 Select **Display Spare Pool Devices** from the Spare Pool menu.
- 3 View the spare pool information that appears on the screen. When you are finished, press any key to return to the Spare Pool menu.

Adding a Dedicated Spare

When you create an array you have the option of adding one or two dedicated spares to it. You can also add dedicated spares to an existing array at a later time.



Note: We recommend that you create a spare pool instead of using dedicated spares. See *Creating and Deleting Spares* on page C-9 for more information.

You *cannot* add dedicated spares to an array if

- The array already has two dedicated spares
- The remaining single disks are not at least as large as the smallest disk in the selected array

Follow these steps to add one or two dedicated spares to an array:

- 1 Select **Disk Array Operations** from the Main Menu.
- 2 Select **Add/Delete Spare Drive** from the Disk Array Operations menu.
- 3 Select the array to which you want to add the dedicated spare.
- 4 Select **Add Spare Drive** from the Add/Delete Spare menu.
- 5 Select a SCSI channel on the left, if necessary, and then press → to move to the list of disks on the right. Disks are grayed out if they are already used in an array or if they are smaller than the members of the array. Highlight an available disk and press **Enter**. Then select another disk for the second spare, if necessary. The new dedicated spare is added immediately.



Caution: A warning appears if you select a disk that has partitions. *Do not* select disks with partitions if they have data you want to keep; all data will be erased when the disk becomes a spare.

- 6 Press any key to continue.

Deleting a Dedicated Spare

Follow these steps to delete a dedicated spare:

- 1** Select **Disk Array Operations** from the Main Menu.
- 2** Select **Add/Delete Spare Drive** from the Disk Array Operations menu.
- 3** When the list of spare drives appears, select the one you want to delete and press **Enter**.
- 4** Select **Delete Spare Drive** from the Add/Delete Spare Drive menu. The dedicated spare is deleted immediately.
- 5** Press any key to continue. The former dedicated spare can now be used as a spare in another array or as a member of another array.



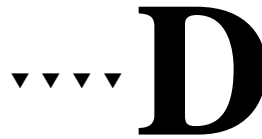

SNMP / DMI Information

Adaptec CI/O Management Software fully supports SNMP and DMI v2.0.

- **SNMP** (Simple Network Management Protocol) is used to allow a network management station to monitor workstations and devices on the network. The management station displays and updates information about the devices monitored by CI/O. System devices are managed with an SNMP *agent*. The *sub-agent* is the software program that implements the monitoring functionality.
- **DMI** is a local interface, meaning that all elements are resident on a single workstation or server platform. DMI itself consists of the Service Layer, the Management and Component Interfaces, and the Management Information Formats (MIFs). DMI is intended to be a protocol-independent, multiplatform interface.

SNMP and DMI are provided for optional integration of CI/O within workgroup or enterprise management solutions. Examples include HP OpenView (SNMP) and Intel LANDesk (DMI). Contact your VAR or OEM for additional information on the use of these industry-standard management technologies.

For more information about how SNMP and DMI are supported under Adaptec CI/O Management Software, see the text documents *cio20.mib* and *io.mif*, respectively, on your installation media.



|

—

|

—

—

|

|

—

▼▼▼▼ Index

A

- Aborting a running activity 7-5
- Activity
 - monitoring 7-6
 - scheduling 7-1
 - viewing activity queue 7-3
- Adaptec CI/O Management Software
 - overview of 1-1
 - starting 4-2
 - tips for using 1-2
- Adding a dedicated spare 4-15
- Adding a dedicated spare (AC) C-11
- Adding a new server address 2-1
- Advanced array options
 - restoring defaults 4-10
 - setting 4-9
- arconfig
 - see *ArrayConfigSA*
- Array
 - blinking drive lights 6-9
 - bootable, creating 4-10
 - booting from (AC) C-2
 - creating 4-4-4-9
 - creating (AC) C-2-C-5
 - critical status 9-1
 - deleting 4-12
 - deleting (AC) C-6
 - initializing 4-13
 - off-line status 9-5
 - optimizing performance 9-7
 - pausing I/O to 6-5
 - reactivating when off-line 6-10
 - reconstructing 6-2

- renaming 6-11
 - setting advanced options 4-9
 - size of disks 9-7
 - verifying 6-7
 - viewing information for 5-2
 - viewing information for (AC) C-6
- Array performance
 - optimizing 9-7
 - ArrayConfigSA*
 - creating an array C-2
 - deleting an array C-6
 - displaying array information C-6

B

- Boot order, changing (AC) C-5
- Bootable array
 - creating 4-10
 - creating (AC) C-5
- Bridge controllers
 - viewing and configuring arrays 3-2, 4-19

C

- Changing an activity's priority 7-4
- Changing filter options 2-9
- Channel information
 - viewing 3-6, 5-9
- Choosing notification settings 2-10
- Configuration file A-4
- Controller information
 - viewing 5-7
- Conventions, formatting 1-3
- Creating a boot array 4-10

Adaptec C/I/O Management Software User's Guide

Creating a boot array (AC) C-5
Creating an array 4-4-4-9
Creating an array (AC) C-2
Critical status
 responding to 9-1

D

Dedicated spare
 adding 4-15
 adding (AC) C-11
 defined C-9
 deleting 4-18
 deleting (AC) C-12
Deleting a dedicated spare
 (AC) C-12
Deleting a scheduled activity 7-5
Deleting a server address 2-6
Deleting a spare pool disk
 (AC) C-10
Deleting an array 4-12
Deleting an array (AC) C-6
Device icons 3-3, 5-1
Downing a disk drive 6-16
Drive light
 blinking for array 6-9
 blinking for device 6-15
 blinking for spare 6-14

E

Editing the permanent list 2-14
Entering and viewing options
 settings 2-13
Event notifications
 setting options for 2-13
 severity levels 2-12

F

Filter options, changing 2-9
Forcing a spare 6-11

G

Guest access 8-4
gui.ini A-4

H

Hot swapping 6-3

I

.ini files A-1
I/O Manager
 settings A-7
Icons 3-3, 5-1
Initializing an array 4-13
Initializing an array (AC) C-7
iomgr.ini A-2
IP/IPX protocol 2-2

L

Low-level formatting
 advantages and
 disadvantages C-7

M

Monitoring an activity 7-3

O

Off-line array
 reactivating 6-10
Off-line status, responding to 9-5
Optimizing array performance 9-7

P

Parity
 verifying for array 6-7
Partitions, checking for 4-6
Password 8-1
 changing 8-2
 guest access 8-4

- time-out options 8-3
- Pausing/Resuming I/O
 - to a device 6-17
 - to an array 6-5
- Permanent list, editing 2-14
- Polling the driver A-2
- Preferences dialog box 2-13

R

- RAID Activity Monitor 7-4
- RAID level
 - RAID 0 9-8
 - RAID 0/1 9-9
 - RAID 1 9-9
 - RAID 5 9-10
 - selecting 9-7
- Reactivating an off-line array 6-10
- Reconstructing an array 6-2
- Recreate operation A-2
- Renaming an array 6-11
- Rescanning the server 3-7, 5-5
- Running activity
 - aborting 7-5
 - monitoring 7-6

S

- Scheduler dialog box 7-2
- Scheduling a new activity 7-2
- Scheduling options
 - setting 7-1
- SCSI adapter
 - viewing information 3-5
- SCSI device
 - blinking drive lights 6-15
 - pausing I/O to 6-17
 - viewing information 3-4, 5-5
- Server address
 - adding 2-1
 - deleting 2-6
- Server configuration file A-4

- Server events
 - viewing a list of 2-6
- Server Historic Event Log
 - changing filter options 2-9
 - notification settings 2-10
- Server information
 - viewing 2-11
 - viewing and editing 2-4
- Server view A-4
- Server, scanning 5-5
- Setting advanced array options 4-9
- Spare
 - viewing information for 5-4
- Spare pool
 - creating 4-15
 - creating (AC) C-9
 - defined C-9
 - deleting disk from 4-18
 - limitations of C-10
 - viewing information for 4-16
- Spare, dedicated
 - adding (AC) C-11
 - deleting 4-18
 - deleting (AC) C-12
- Spare, forcing 6-11
- Spares
 - testing 6-13
- Stripe size 4-9

T

- Test all spares operation A-3
- Testing all spares 6-13

V

- Verifying an array 6-7, A-2
- Viewing a list of server events 2-6
- Viewing array information 5-2
- Viewing channel information 5-9
 - SCSI adapters 3-6
- Viewing controller information 5-7

Adaptec C/I/O Management Software User's Guide

Viewing historical server
information 2-11

Viewing SCSI adapter
information 3-5

Viewing SCSI device
information 3-4, 5-5

Viewing spare information 5-4

Viewing/editing server
information 2-4

